

CINQUE[≡]

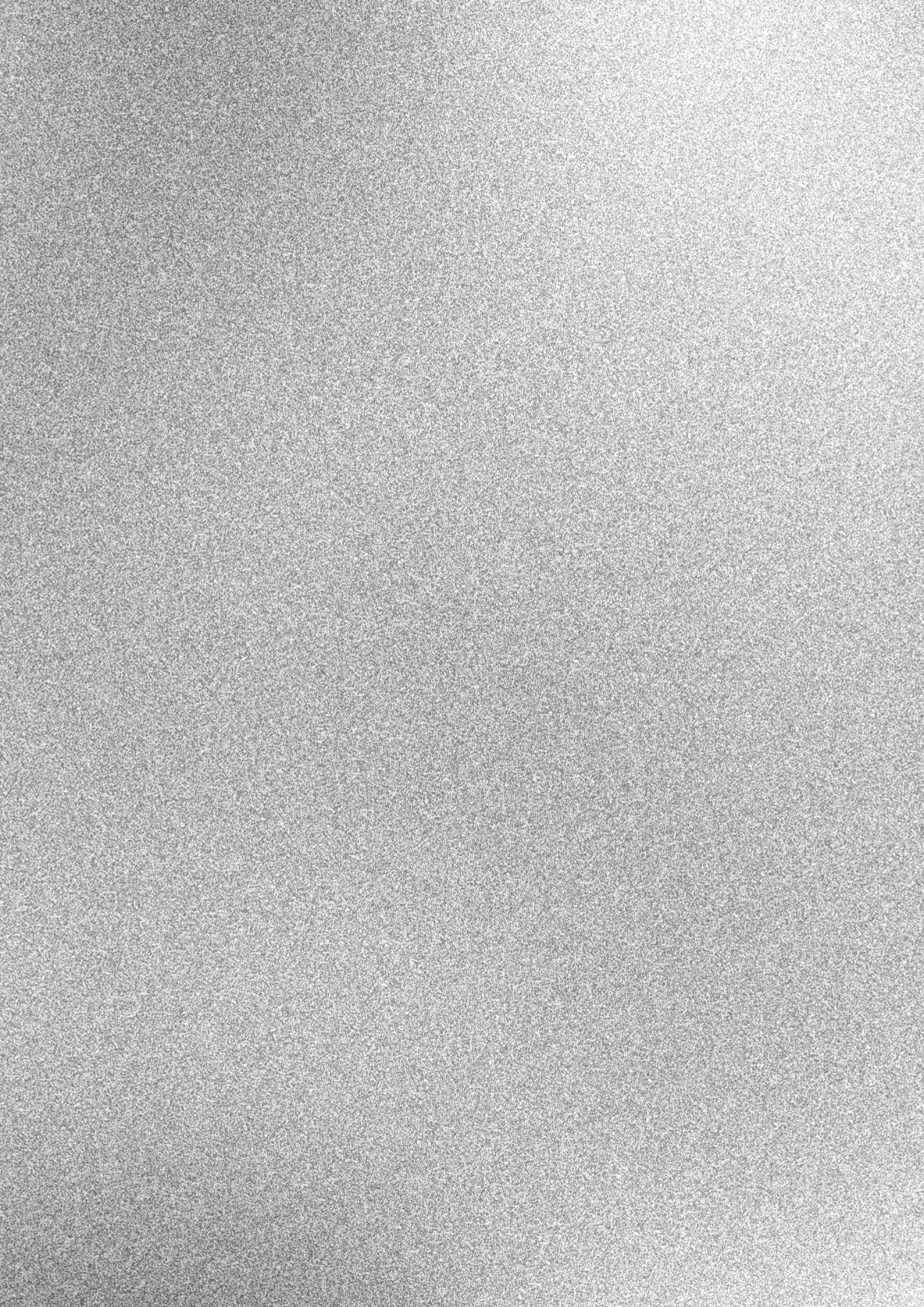

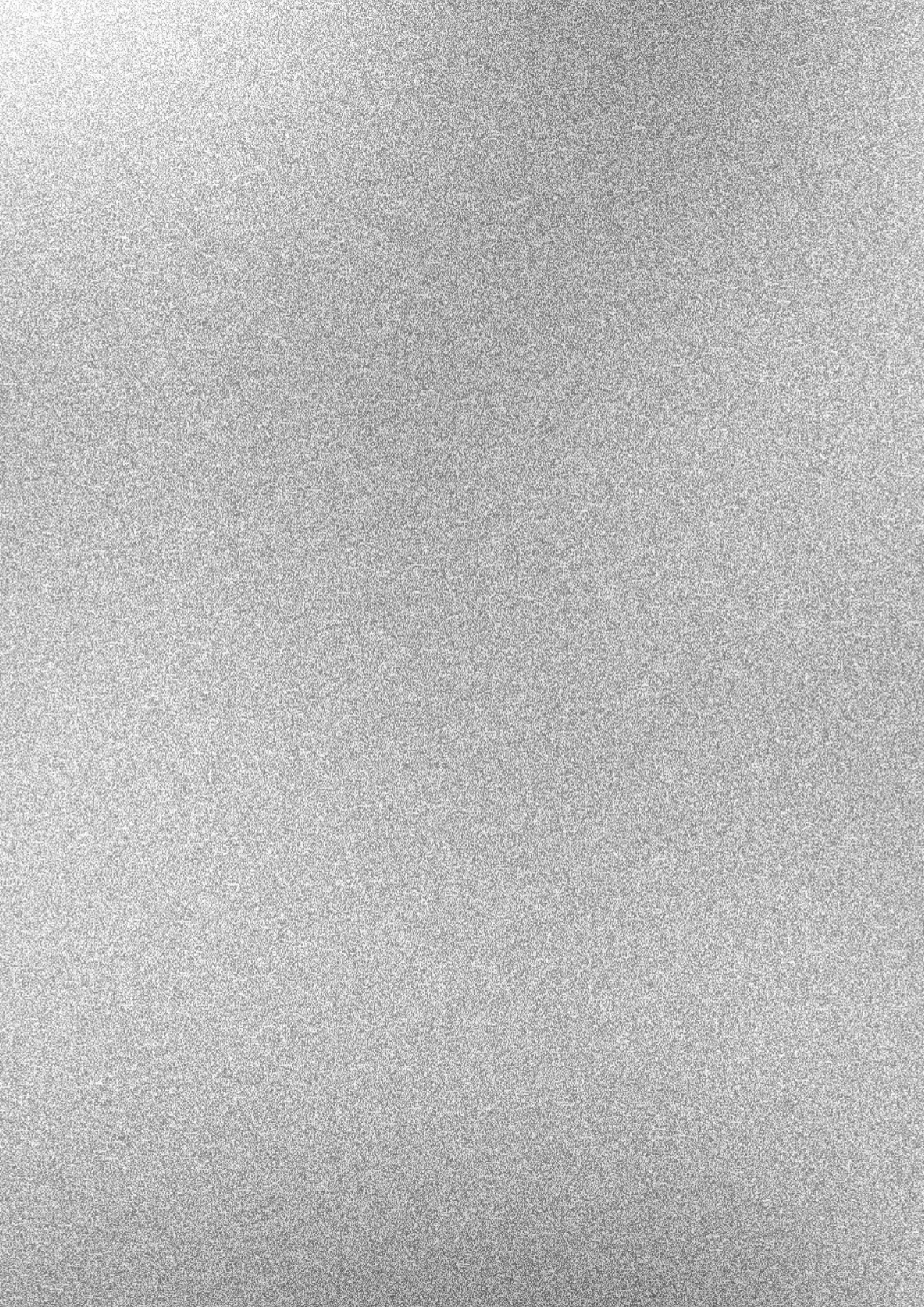





ENJOY YOUR LIGHT.

CINQUE 

CINQUE präsentiert eine unverwechselbare Leuchten-Kollektion, die ebenso lebendig wie anmutig ist. Qualitativ hochwertige Lichtobjekte, die elegant-stilvolles Design mit modernster Technologie vereinen und sich nicht zuletzt durch beeindruckende Lichteigenschaften auszeichnen. Das Zusammenspiel innovativer Materialien und funktionaler Finesse machen die Leuchten zu etwas ganz Besonderem. So wird Licht nicht nur zum Erlebnis, sondern verleiht Lebensräumen ästhetische und emotionale Qualität.

CINQUE presents a distinctive lighting collection that is as lively as it is graceful. High-quality lighting objects that combine elegant, stylish design with state-of-the-art technology and, last but not least, are characterised by impressive lighting properties. The interplay of innovative materials and functional finesse make the luminaires something very special. In this way, light not only becomes an experience, but also gives living spaces aesthetic and emotional quality.

76

CINQUE 

6

CICENZA | **44**

CICANTO | **50**

CIVETO | **58**

CIFAVO | **64**

CIZIONE | **70**

CIPERA | **76**

32

36

40

CISENNA

DIE KUNST, LICHT ZUM AUSDRUCK ZU BRINGEN
THE ART OF EXPRESSING LIGHT



Es gibt Dinge, die nicht laut sein müssen, um Eindruck zu hinterlassen. Die Serie CISENNA verkörpert modernes Design mit einer sinnlichen Note. Mit ihrer fließenden Form und eindrucksvollen Präsenz zieht sie alle Blicke auf sich und verleiht jedem Raum eine Aura von Eleganz und Ausdruckskraft. Ihre großzügige Silhouette wirkt wie eine Skulptur aus Licht – weich in der Linie, stark in der Wirkung. CISENNA verbindet moderne Formensprache mit einem Hauch von Luxus und schafft so eine Atmosphäre, die inspiriert und beeindruckt. Ob über dem Esstisch, in offenen Wohnbereichen oder in repräsentativen Räumen – CISENNA ist für all jene geschaffen, die Räume nicht nur gestalten, sondern inszenieren möchten. Hier wird Licht zur Sprache – leise, aber unvergesslich.

There are things that don't have to be loud to make an impression. The CISENNA series embodies modern design with a sensual touch. With its flowing form and impressive presence, it attracts everyone's attention and gives every room an aura of elegance and expressiveness. Its generous silhouette looks like a sculpture of light – soft in line, strong in effect. CISENNA combines modern design language with a touch of luxury, creating an atmosphere that inspires and impresses. Whether above the dining table, in open-plan living areas or in prestigious rooms – CISENNA is created for all those who not only want to design rooms, but also stage them. Light becomes a language here – quietly, but unforgettably.



CISENNA

DIE KUNST, LICHT ZUM AUSDRUCK ZU BRINGEN
THE ART OF EXPRESSING LIGHT

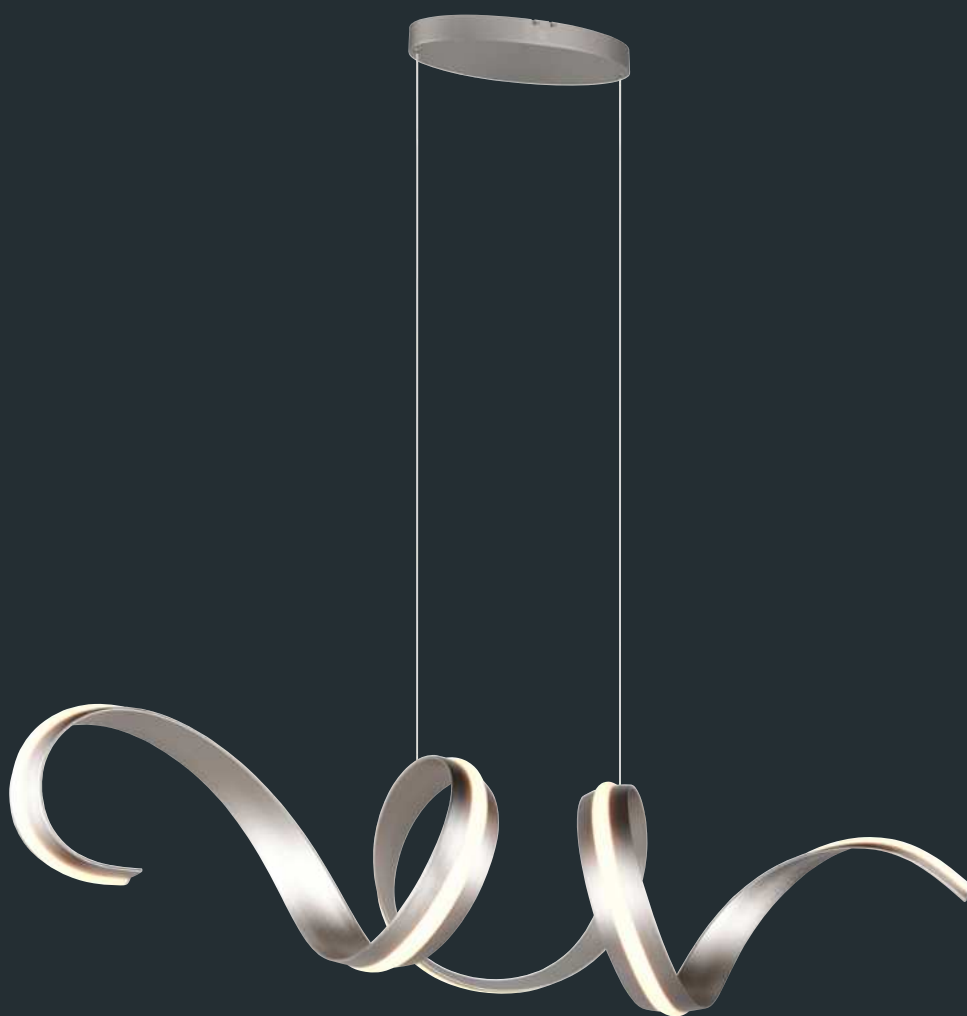

CISENNA

Pendelleuchte, Metall
Pendant lamp, metal

↔ 1600 mm ↓ 3.000 mm ↗ 460 mm

SMD-LED, 80 W, 10.000 lm

2.000 - 4.000 K

336119107 | Nickel matt · Nickel mat

336119132 | Schwarz matt · Black mat

336119143 | Warm beige · Warm beige

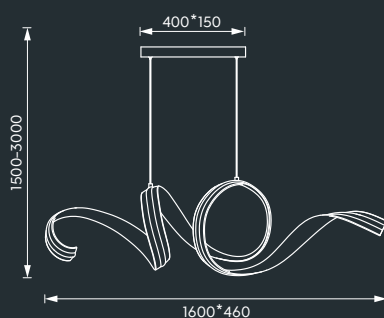



CISENNA

DIE KUNST, LICHT ZUM AUSDRUCK ZU BRINGEN
THE ART OF EXPRESSING LIGHT

CI-MOTE
ready

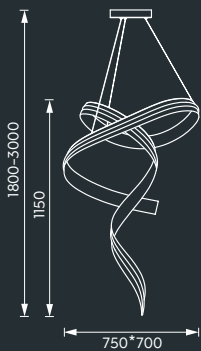

CISENNA

Pendelleuchte, Metall
Pendant lamp, metal

↔ 750 mm ↓ 3.000 mm ↗ 700 mm

SMD-LED, 80 W, 10.000 lm

2.000 - 4.000 K

336130107 | Nickel matt · Nickel mat

336130132 | Schwarz matt · Black mat

336130143 | Warm beige · Warm beige





CISENNA

DIE KUNST, LICHT ZUM AUSDRUCK ZU BRINGEN
THE ART OF EXPRESSING LIGHT

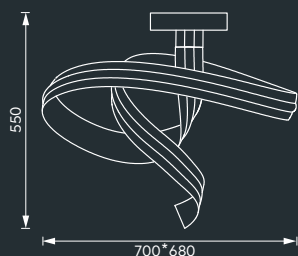

CISENNA

Deckenleuchte, Metall
Ceiling lamp, metal

↔ 700 mm ↓ 550 mm ↗ 680 mm

SMD-LED, 46 W, 5.600 lm

2.000 - 4.000 K

636110107 | Nickel matt · Nickel mat

636110132 | Schwarz matt · Black mat

636110143 | Warm beige · Warm beige





CISENNA

DIE KUNST, LICHT ZUM AUSDRUCK ZU BRINGEN
THE ART OF EXPRESSING LIGHT

CI-MOTE
ready



CISENNA

Tischleuchte, Metall
Table lamp, metal

↔ 220 mm ↑ 605 mm ↗ 200 mm

SMD-LED, 17 W, 2.100 lm

2.000 - 4.000 K

536110107 | Nickel matt · Nickel mat

536110132 | Schwarz matt · Black mat

536110143 | Warm beige · Warm beige



CISENNA

Stehleuchte, Metall
Floor lamp, metal

↔ 310 mm ↑ 1.800 mm ↗ 300 mm

SMD-LED, 52 W, 6.200 lm

2.000 - 4.000 K

436110107 | Nickel matt · Nickel mat

436110132 | Schwarz matt · Black mat

436110143 | Warm beige · Warm beige





CINARDI

ELEGANTE LICHTKUNST ELEGANT LIGHT ART

Die faszinierende Leuchtenserie CINARDI vereint zeitlose Eleganz mit innovativer LED-Technologie. Die ausdrucksstarke Formensprache sowie die brillanten Lichteigenschaften vermitteln unbeschwerter Leichtigkeit und sorgen für ein angenehm entspanntes Wohngefühl. Mit einem Durchmesser von 75 cm kommt die Pendelleuchte besonders in großzügig gestalteten Wohnbereichen eindrucksvoll zur Geltung. In Kombination mit der passenden Tisch- und Bodenleuchte entstehen so faszinierende Beleuchtungsszenarien. Die Serie ist in Nickel gebürstet, Mattschwarz, Taupe und Dark chocolat erhältlich.

The fascinating CINARDI luminaire series combines timeless elegance with innovative LED technology. The expressive design language and brilliant lighting properties convey a carefree lightness and ensure a pleasantly relaxed atmosphere. With a diameter of 75 cm, the pendant light is particularly effective in spacious living areas. In combination with the matching table and floor lamps, it creates fascinating lighting scenarios. The series is available in brushed nickel, matte black, taupe and dark chocolate.





CINARDI

ELEGANTE LICHTKUNST
ELEGANT LIGHT ART

CI-MOTE
ready

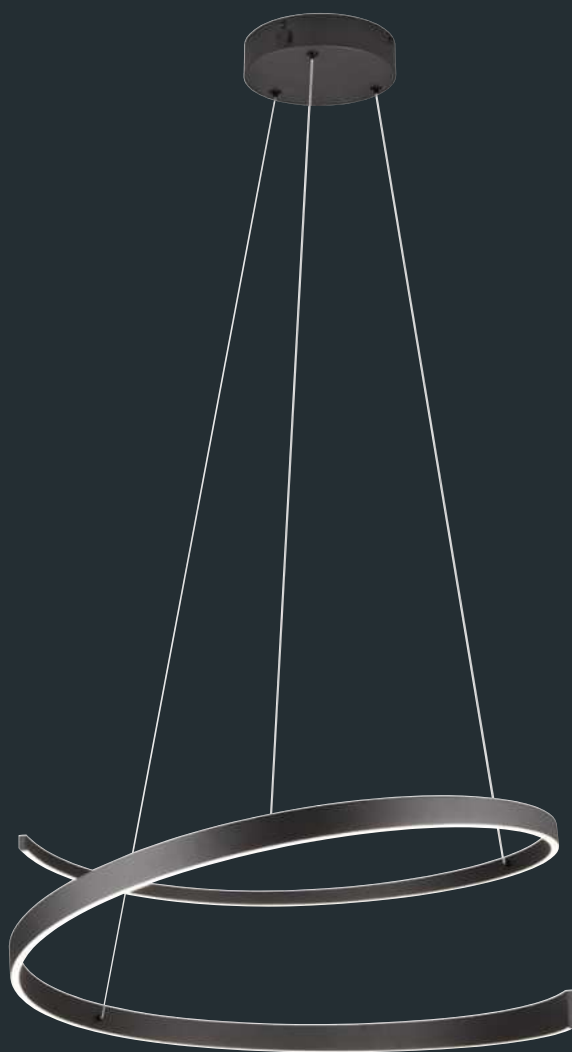
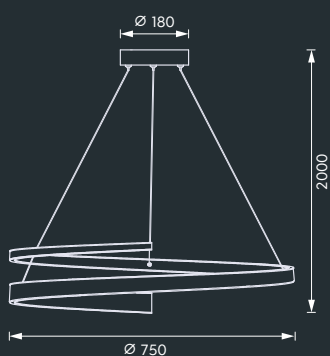

CINARDI

Pendelleuchte, Metall
Pendant lamp, metal

↔ 750 mm ↓ 2.000 mm

SMD-LED, 50 W, 5.950 lm

2.000 - 4.000 K

346110107 | Nickel matt · Nickel mat

346110132 | Schwarz matt · Black mat

346110141 | Taupe

346110168 | Dark chocolate





CINARDI

ELEGANTE LICHTKUNST

ELEGANT LIGHT ART

CI-MOTE
ready

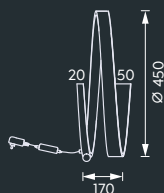
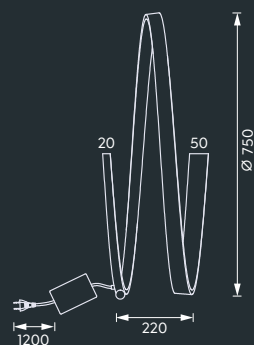
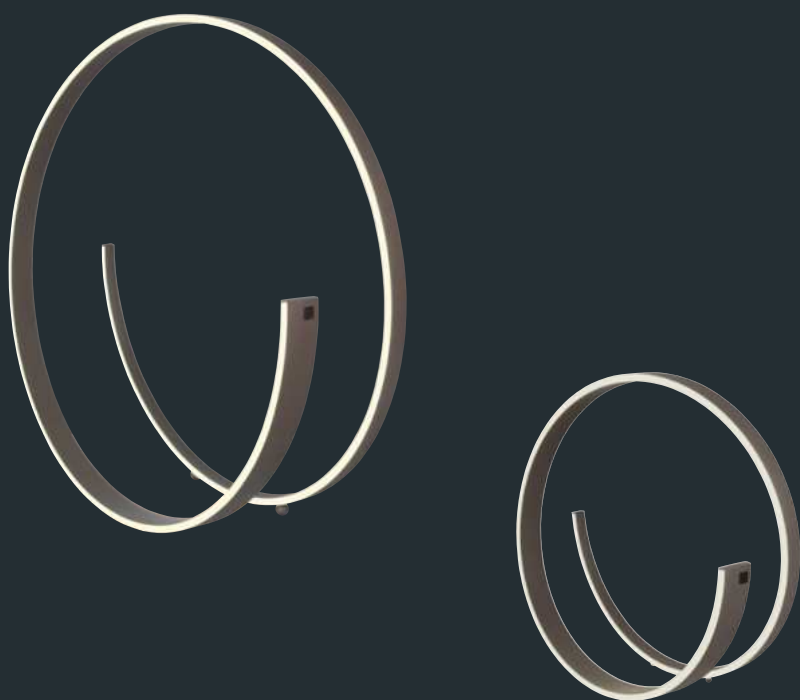

CINARDI

Stehleuchte, Metall
Floor lamp, metal

↔ 220 mm ↑ Ø 750 mm

SMD-LED, 42 W, 4.900 lm

2.000 - 4.000 K

446110107 | Nickel matt · Nickel mat

446110132 | Schwarz matt · Black mat

446110141 | Taupe

446110168 | Dark chocolate



CINARDI

Tischleuchte, Metall
Table lamp, metal

↔ 170 mm ↑ Ø 450 mm

SMD-LED, 21 W, 2.400 lm

2.000 - 4.000 K

546110107 | Nickel matt · Nickel mat

546110132 | Schwarz matt · Black mat

546110141 | Taupe

546110168 | Dark chocolate

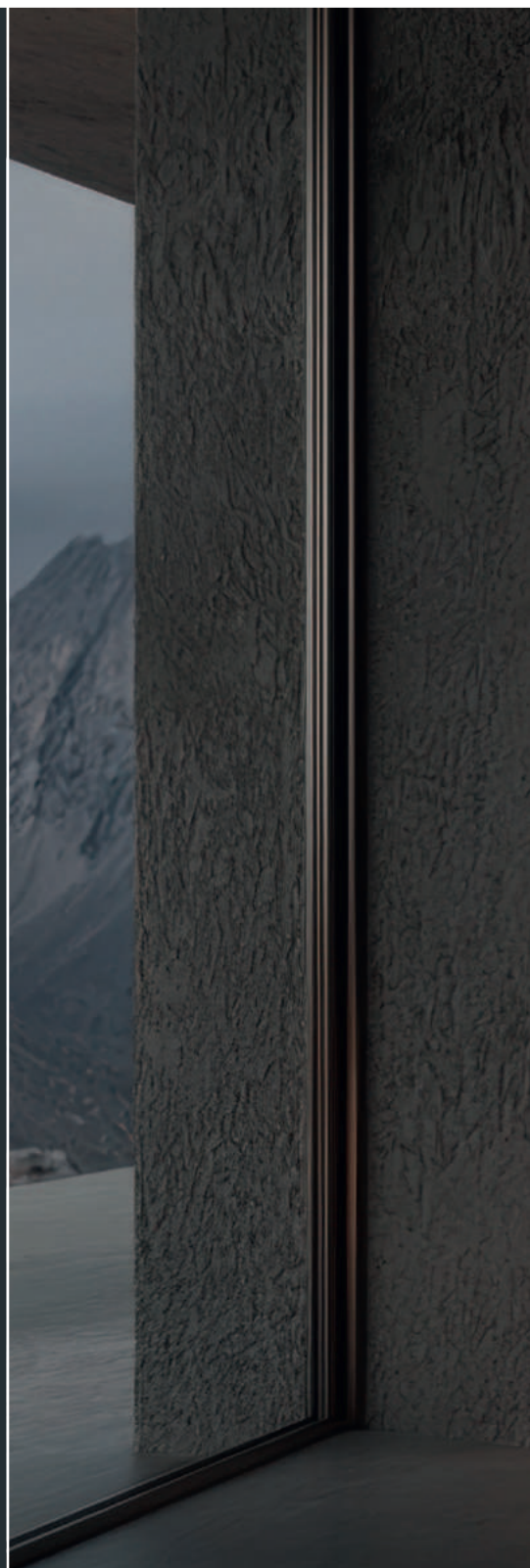



CINARDI

ELEGANTE LICHTKUNST
ELEGANT LIGHT ART

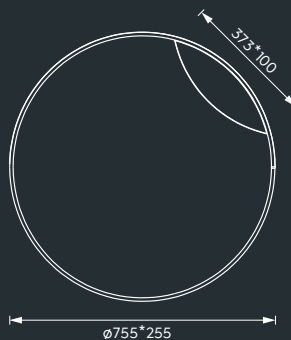
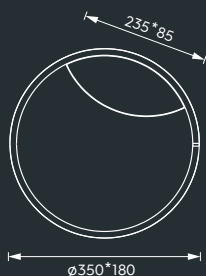
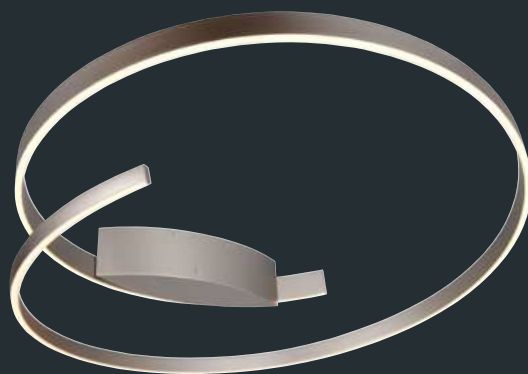

CINARDI

Wand- und Deckenleuchte, Metall
Wall and ceiling lamp, metal

↔ 180 mm ↑ Ø 350 mm

SMD-LED, 15 W, 2.400 lm

2.000 - 4.000 K

246110107 | Nickel matt · Nickel mat

246110132 | Schwarz matt · Black mat



CINARDI

Deckenleuchte, Metall
Ceiling lamp, metal

↔ 255 mm ↑ Ø 755 mm

SMD-LED, 48 W, 7.200 lm

2.000 - 4.000 K

646110107 | Nickel matt · Nickel mat

646110132 | Schwarz matt · Black mat





CIOLA

IMPOSANT UND REPRÄSENTATIV
IMPRESSIVE AND DISTINGUISHED





Imposant und repräsentativ zeigen sich die Leuchten aus der Serie CIOLA. Das perfekte Zusammenspiel von Opulenz und spielerischer Leichtigkeit macht die Leuchten einzigartig und überraschend emotional. So passt sich die Serie gleichermaßen in moderne Räume und auch in klassische Wohnkonzepte ein. Das gilt insbesondere für Wohnbereiche, in denen die Leuchte gerne mal im Mittelpunkt stehen darf. Ob in den Ausführungen Schwarz, edlem Nickel matt oder Taupe, die Serie CIOLA lässt keine Wünsche offen und verspricht maximalen Lichtkomfort.

The lamps from the CIOLA series are impressive and distinguished. The perfect interplay of opulence and playful ease makes the lamps unique and surprisingly evocative. Therefore the series fits equally into modern rooms as well as into classic living concepts. This applies in particular to living areas where the lamp may be the centre of attention. Whether in the black, elegant nickel matte or taupe, the CIOLA series leaves nothing to be desired and promises maximum lighting comfort.

CIOLA

IMPOSANT UND REPRÄSENTATIV
IMPRESSIVE AND DISTINGUISHED

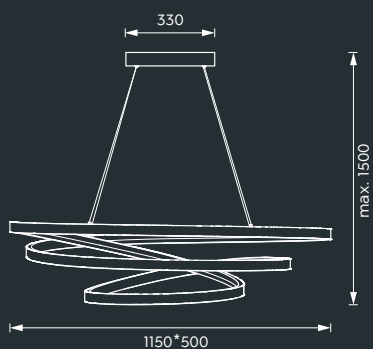

CIOLA

Pendelleuchte, Metall Acryl
Pendant lamp, metal acryl

↔ 1.150 mm ↓ 1.500 mm ↗ 500 mm

SMD-LED, 100 W, 11.900 lm

2.000 - 4.000 K

377210107 | Nickel matt · Nickel mat

377210132 | Schwarz matt · Black mat

377210141 | Taupe





CIOLA

IMPOSANT UND REPRÄSENTATIV
IMPRESSIVE AND DISTINGUISHED

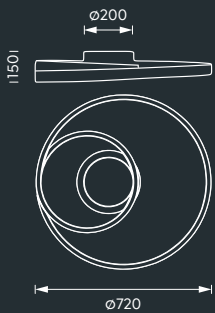
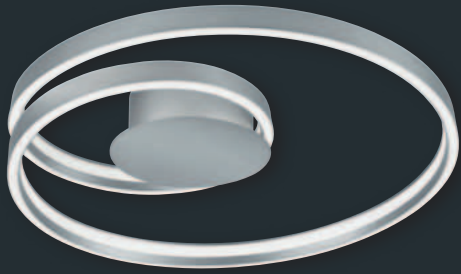

CIOLA

Deckenleuchte, Metall Acryl
Ceiling lamp, metal acryl

↔ Ø 720 mm ↓ 150 mm

SMD-LED, 46 W, 5.400 lm

2.000 - 4.000 K

677210107 | Nickel matt · Nickel mat

677210132 | Schwarz matt · Black mat

677210141 | Taupe



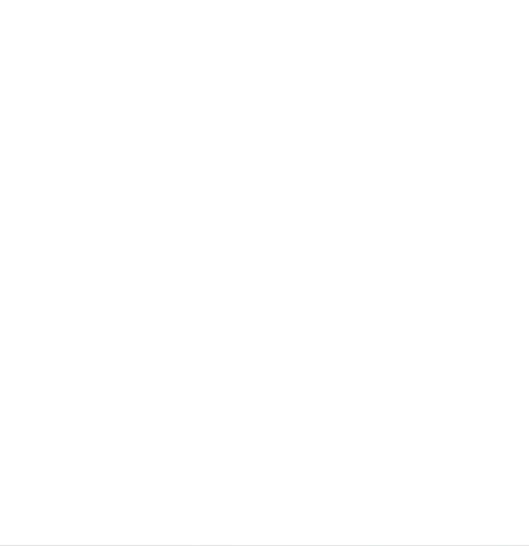

CIOLA

IMPOSANT UND REPRÄSENTATIV
IMPRESSIVE AND DISTINGUISHED

CI-MOTE
ready



CIOLA

Stehleuchte, Metall Acryl
Floor lamp, metal acryl

↔ 500 mm ↑ 1.750 mm

SMD-LED, 62 W, 7.300 lm

2.000 - 4.000 K

477210107 | Nickel matt · Nickel mat

477210132 | Schwarz matt · Black mat



CIOLA

Tischleuchte, Metall Acryl
Table lamp, metal acryl

↔ 260 mm ↑ 650 mm

SMD-LED, 21 W, 2.350 lm

2.000 - 4.000 K

577210107 | Nickel matt · Nickel mat

577210132 | Schwarz matt · Black mat





CIVASTO

LICHT, DAS RÄUME VERWANDELT
LIGHT THAT TRANSFORMS SPACES

CIVASTO ist kein gewöhnliches Lichtobjekt – es ist ein Erlebnis aus Licht, Raum und Ästhetik. Vom Boden bis zur Decke gespannt, verbindet CIVASTO minimalistisches Design mit maximaler Wirkung. Dieses Licht ist kein Beiwerk – es ist ein Gefühl. Es fließt nicht einfach – es erhebt. Es schafft Tiefe, lenkt den Blick nach oben und lässt Räume größer, freier und lebendiger wirken. CIVASTO bringt nicht nur Helligkeit, sondern eine stille Poesie in jede Umgebung. Ob im privaten Rückzugsort oder in einem offenen, modernen Ambiente: CIVASTO verbindet Architektur mit Emotion – und macht aus jedem Raum ein Erlebnis.

CIVASTO is not an ordinary light object – it is an experience of light, space and aesthetics. Stretched from floor to ceiling, CIVASTO combines minimalist design with maximum impact. This light is not an accessory – it is a feeling. It doesn't just flow – it uplifts. It creates depth, directs the gaze upwards and makes rooms appear larger, freer and livelier. CIVASTO brings not only brightness, but a quiet poetry to any environment. Whether in a private retreat or in an open, modern ambience: CIVASTO combines architecture with emotion – and turns every room into an experience.





CIVASTO

LICHT, DAS RÄUME VERWANDELT
LIGHT THAT TRANSFORMS SPACES

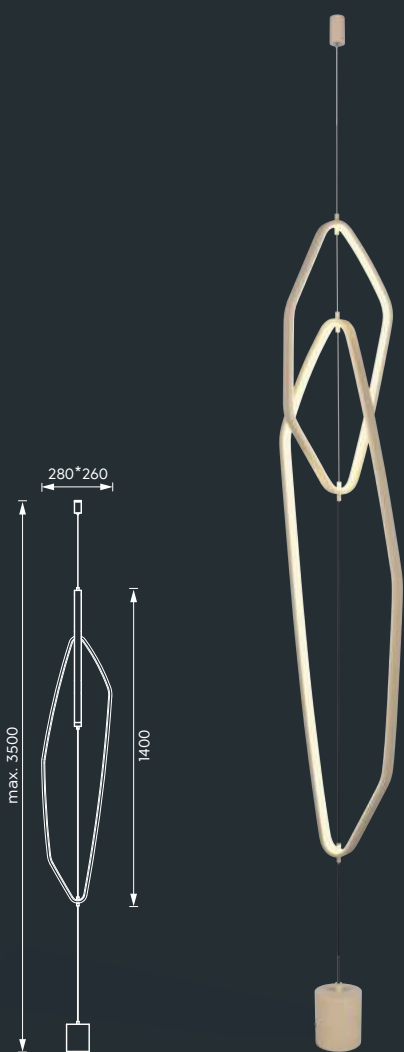

CIVASTO

Stehleuchte, Metall
Floor lamp, metal

↔ 280 mm ↓ max. 3.500 mm ↗ 260 mm

SMD-LED, 29 W, 3.370 lm

2.000 - 4.000 K

455810207 | Nickel matt · Nickel mat

455810232 | Schwarz matt · Black mat

455810243 | Warm beige · Warm beige





CIALTO

FÜR RÄUME MIT STIL UND SUBSTANZ
FOR ROOMS WITH STYLE AND SUBSTANCE





CIALTO ist mehr als eine Stehleuchte – sie ist ein Designobjekt mit Charakter. Mit ihrem markanten, kegelförmigen Fuß steht sie fest und selbstbewusst im Raum – wie ein skulpturales Statement, das Ruhe und Charakter ausstrahlt. Ihr außergewöhnliches Design fügt sich harmonisch in moderne Wohnwelten ein und setzt zugleich einen bewussten Akzent. Das Licht von CIALTO ist weich, warm und einladend – ideal, um eine gemütliche Atmosphäre zu schaffen. Ob neben dem Sofa, als stimmungsvolle Beleuchtung in einer Leseecke oder als eleganter Solitär: CIALTO bringt nicht nur Licht ins Wohnzimmer, sondern auch Persönlichkeit.

CIALTO is more than a floor lamp – it is a design object with character. With her distinctive, cone-shaped foot, she stands firmly and confidently in the room – like a sculptural statement that exudes calm and character. Its extraordinary design blends harmoniously into modern living environments and at the same time sets a deliberate accent. The light from CIALTO is soft, warm and inviting – ideal for creating a cosy atmosphere. Whether next to the sofa, as atmospheric lighting in a reading corner or as an elegant solitaire: CIALTO not only brings light into the living room, but also personality.

CIALTO

FÜR RÄUME MIT STIL UND SUBSTANZ
FOR ROOMS WITH STYLE AND SUBSTANCE

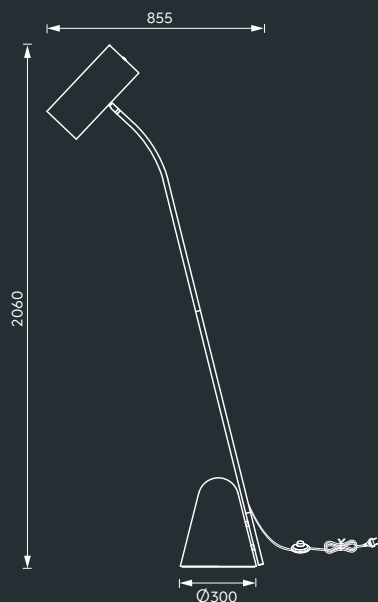

CIALTO

Stehleuchte, Metall
Floor lamp, metal

↔ 300 mm ↓ 2.060 mm ↗ 855 mm

1 x E27, 25 W, 806 lm

2.200 + 2.700 + 3.000 K

467900132 | Schwarz matt · Black mat

467900143 | Warm beige · Warm beige





CIMOLTO

REDUKTION TRIFFT RAFFINESSE
REDUCTION MEETS SOPHISTICATION

Klar in der Linie, durchdacht im Detail: Die Pendelleuchte CIMOLTO vereint ästhetische Zurückhaltung mit technischer Finesse. Ihr minimalistisches Design fügt sich harmonisch in moderne Wohnräume ein – dezent im Stil, mit spürbarer Präsenz. Die integrierte LiftMe-Technik ermöglicht eine mühelose, stufenlose Höhenverstellung – intuitiv und ganz ohne Kraftaufwand. So passt sich CIMOLTO jeder Situation an: als fokussiertes Licht beim Dinner oder als sanfte Hintergrundbeleuchtung für entspannte Abende.

Clear in line, well thought-out in detail: the CIMOLTO pendant luminaire combines aesthetic restraint with technical finesse. Its minimalist design blends harmoniously into modern living spaces – discreet in style, with a noticeable presence. The integrated LiftMe technology enables effortless, infinitely variable height adjustment – intuitively and without any effort. In this way, CIMOLTO adapts to any situation: as a focused light at dinner or as a soft back-light for relaxed evenings.





CIMOLTO

REDUKTION TRIFFT RAFFINESSE
REDUCTION MEETS SOPHISTICATION

CI-MOTE
ready

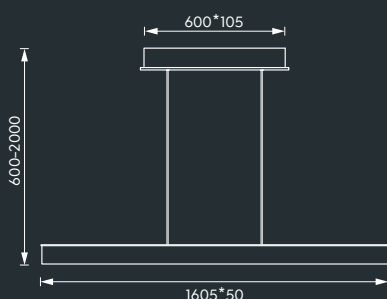
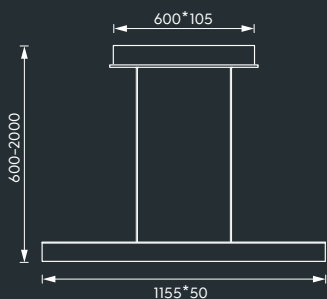
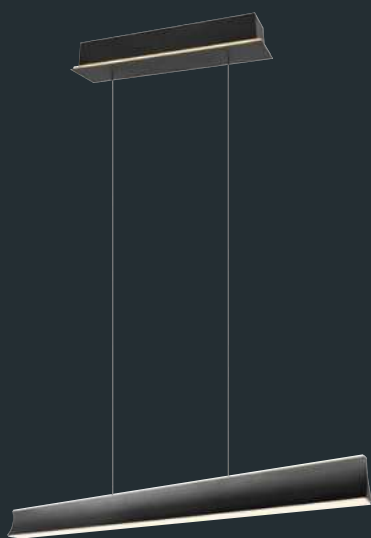

CIMOLTO

Pendelleuchte, Metall
Pendant lamp, metal

↔ 1.155 mm ↓ 2.000 mm ↗ 140 mm

SMD-LED, 41 W, 4.800 lm

2.000 - 4.000 K

335710107 | Nickel matt · Nickel mat

335710132 | Schwarz matt · Black mat



CIMOLTO

Pendelleuchte, Metall
Pendant lamp, metal

↔ 1.605 mm ↓ 2.000 mm ↗ 140 mm

SMD-LED, 50 W, 5.850 lm

2.000 - 4.000 K

335719107 | Nickel matt · Nickel mat

335719132 | Schwarz matt · Black mat





CICENZA

MODERNE LEICHTIGKEIT
MODERN EASE

Ein Lichtgenuss der besonderen Art. Die Serie CICENZA zeigt sich einzigartig in ihrem Design und verkörpert durch ihre elegant geschwungene Form eine moderne Leichtigkeit. Die seitlich verlaufenden LED-Streifen wirken beinahe magisch und vereinen die exzellente Lichtqualität mit dem lebhaften Profil der Leuchten. Um die Freude am Licht zu unterstreichen, ist die Pendelleuchte dank innovativer Lift-Technik kinderleicht höhenregulierbar – Steh- und Tischleuchte lassen sich spielend leicht um 360° drehen. Die Serie ist lieferbar in Schwarz matt.

The right lighting provides a special kind of enjoyment. The CICENZA series is unique in its design and embodies modern ease with its elegantly curved shape. The LED strips running along the side seem almost magical and combine the excellent light quality with the lively profile of the lights. In order to emphasize the enjoyment of light, the pendant lamp is easy to use thanks to innovative lift technology – floor and table lamps can be easily rotated 360°. The series is available in matte black.

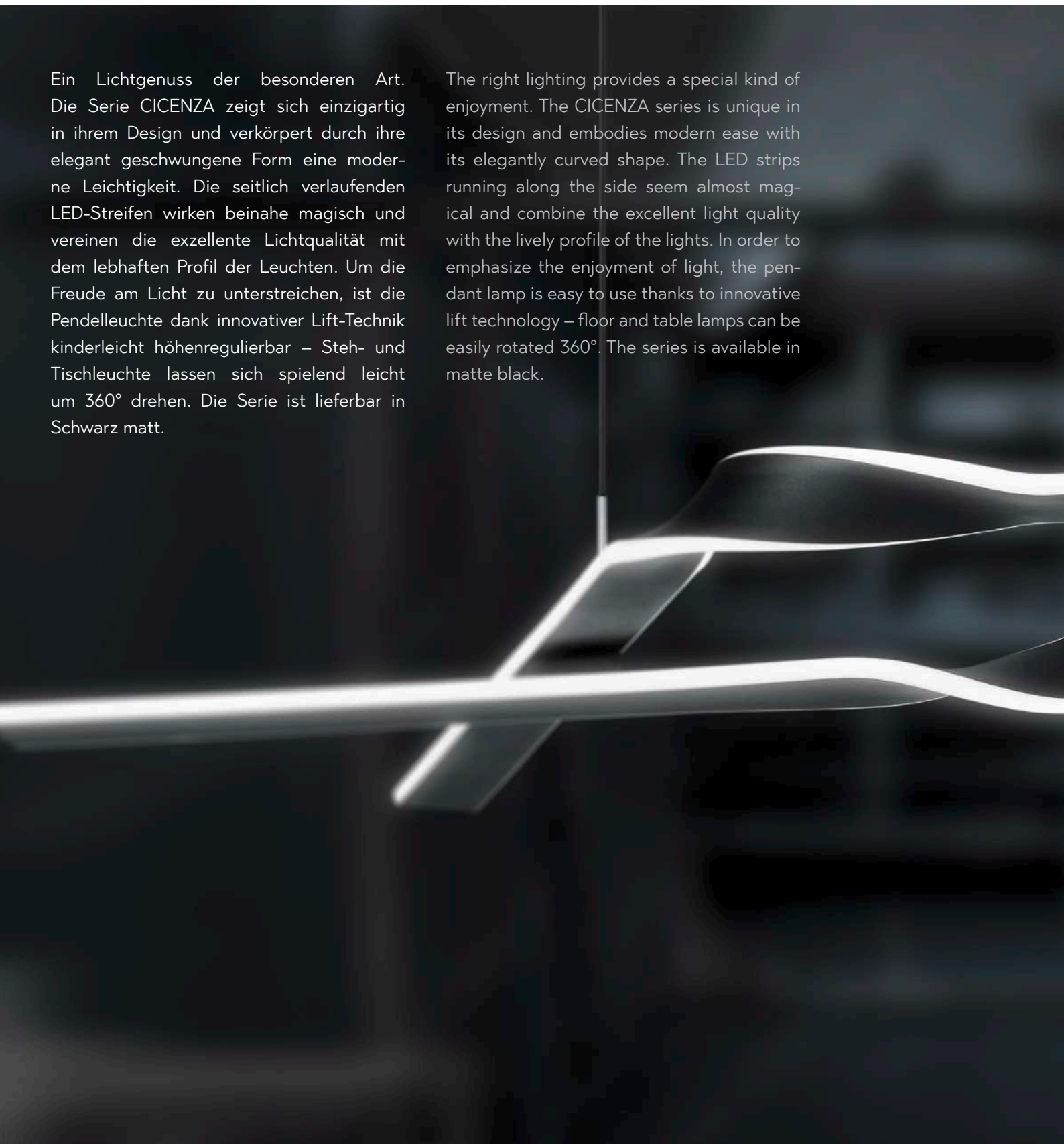



CICENZA

MODERNE LEICHTIGKEIT
MODERN EASE

CI-MOTE
ready

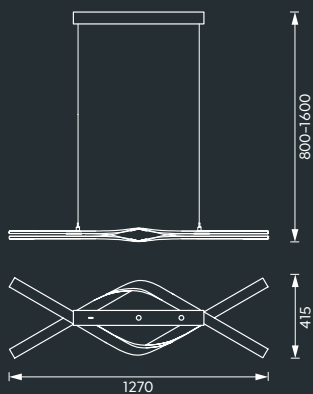
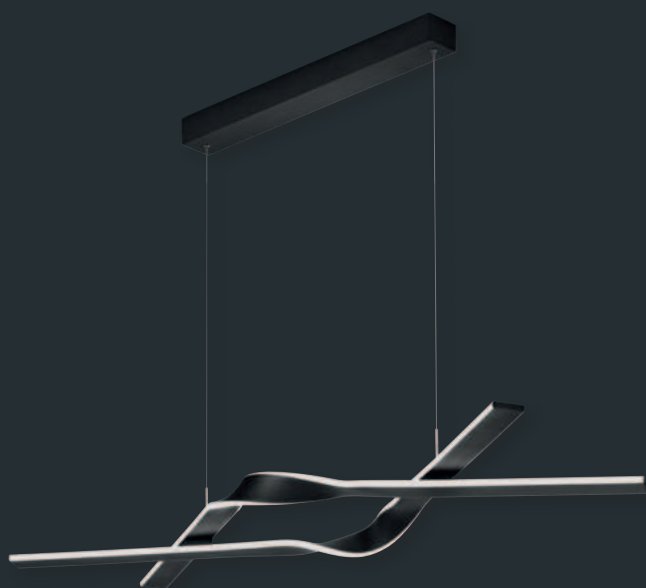

CICENZA

Pendelleuchte, Metall Acryl
Pendant lamp, metal acryl

↔ 1.270 mm ↑ 800-1.600 mm ↗ 415 mm

SMD-LED, 52 W, 6.500 lm

2.000 - 4.000 K

378510232 | Schwarz matt · Black mat

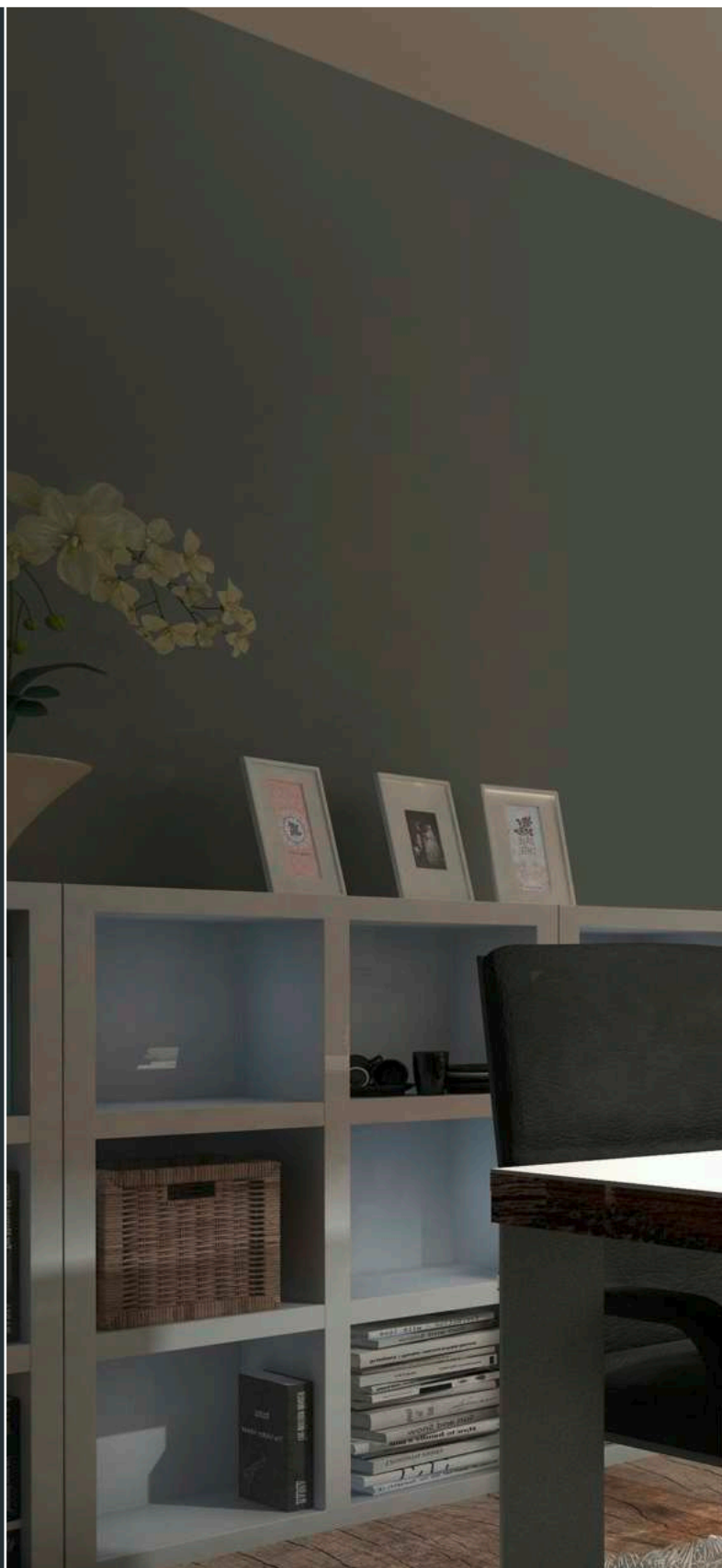



CICENZA

MODERNE LEICHTIGKEIT
MODERN EASE



CICENZA

Stehleuchte, Metall Acryl
Floor lamp, metal acryl

↔ 530 mm ↑ 1.810 mm

SMD-LED, 40 W, 4.700 lm

2.000 - 4.000 K

478510132 | Schwarz matt · Black mat



CICENZA

Tischleuchte, Metall Acryl
Table lamp, metal acryl

↔ 230 mm ↑ 645 mm

SMD-LED, 12 W, 1.300 lm

2.000 - 4.000 K

578510132 | Schwarz matt · Black mat





CICANTO

DESIGN AUF GANZER LINIE
DESIGN ALL ALONG THE LINE

Klares und edles Design sowie eine hohe Wertigkeit zeichnen die puristische Leuchtenserie CICANTO aus. Die Decken- und Pendelleuchten überzeugen durch die ausgewogene Kombination von direktem und indirektem Licht. Die Steh- und Tischleuchten wurden so konstruiert, dass sie sich um 360° – also einmal um die eigene Achse – drehen lassen. Ein einzigartiger Bewegungsradius mit höchstem Komfort, der einfach nur begeistert.

The puristic CICANTO luminaire series is characterised by a clear and elegant design and high quality. The ceiling and pendant luminaires convince with their balanced combination of direct and indirect light. The floor and table luminaires have been designed in such a way that they can be rotated 360° – once around their own axis. A unique range of movement with maximum comfort that simply inspires.



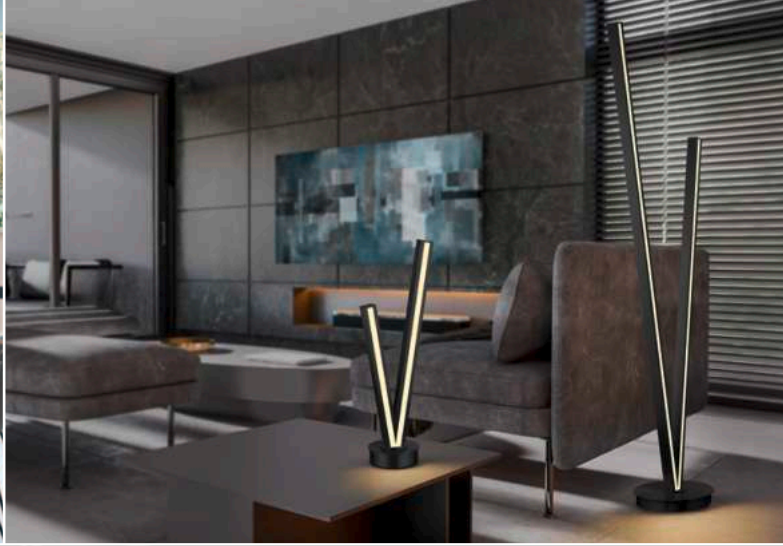

CICANTO

DESIGN AUF GANZER LINIE
DESIGN ALL ALONG THE LINE

CI-MOTE
ready

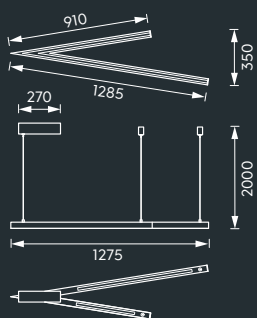
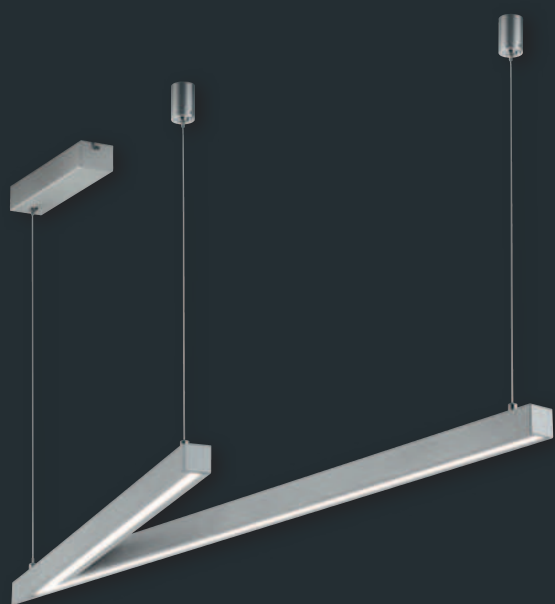

CICANTO

Pendelleuchte, Metall Acryl
Pendant lamp, metal acryl

↔ 1.275 mm ↑ 2.000 mm ↗ 350 mm

SMD-LED, 44 W, 5.050 lm

2.000 - 4.000 K

375010107 | Nickel matt · Nickel mat

375010132 | Schwarz matt · Black mat





CICANTO

DESIGN AUF GANZER LINIE
DESIGN ALL ALONG THE LINE

CI-MOTE
ready

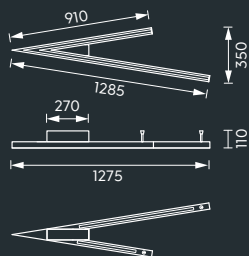
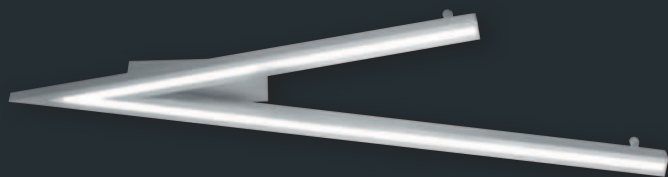

CICANTO

Wand- und Deckenleuchte, Metall Acryl
Wall and ceiling lamp, metal acryl

↔ 1.275 mm ↓ 110 mm ↗ 350 mm

SMD-LED, 44 W, 5.050 lm

2.000 - 4.000 K

675010107 | Nickel matt · Nickel mat

675010132 | Schwarz matt · Black mat





CICANTO

DESIGN AUF GANZER LINIE
DESIGN ALL ALONG THE LINE

CI·MOTE
ready

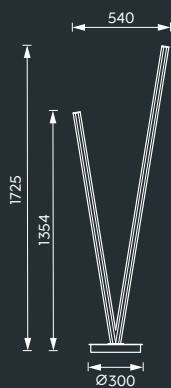
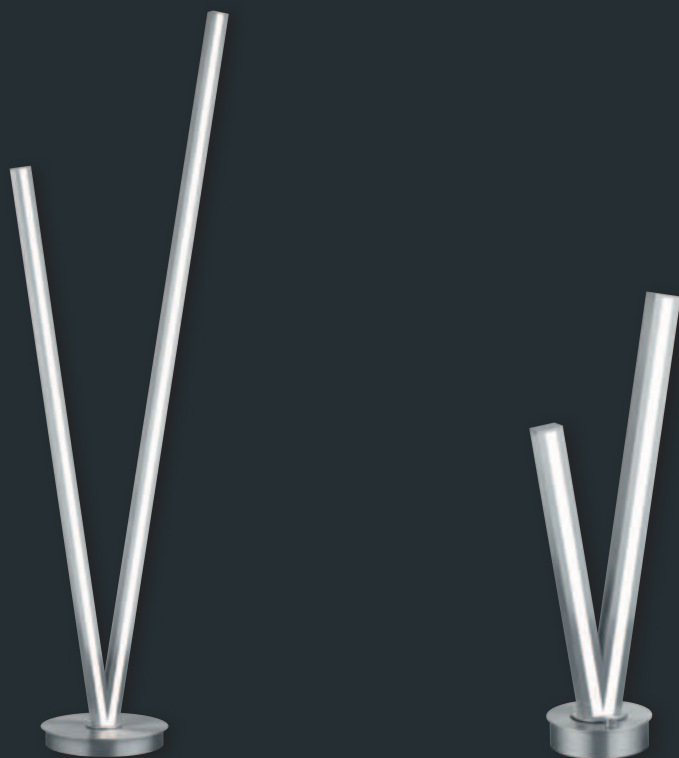

CICANTO

Stehleuchte, Metall
Floor lamp, metal

↔ 540 mm ↑ 1.725 mm ↗ 300 mm

SMD-LED, 45 W, 5.250 lm

2.000 - 4.000 K

475010107 | Nickel matt · Nickel mat

475010132 | Schwarz matt · Black mat



CICANTO

Tischleuchte, Metall
Table lamp, metal

↔ 225 mm ↑ 675 mm ↗ 160 mm

SMD-LED, 15 W, 1.600 lm

2.000 - 4.000 K

575010107 | Nickel matt · Nickel mat

575010132 | Schwarz matt · Black mat





CIVETO

ZEITLOSES DESIGN
TIMELESS DESIGN

Modernes, zeitloses Design und schlichte Eleganz verleihen der Leuchtenserie CIVETO einen einmaligen Charme. Die Pendelleuchte ist in zwei verschiedenen Ausführungen erhältlich und fasziniert durch einen gelungenen Mix aus matt schwarzen und hell silbernen Aluminiumoberflächen. Spielend leicht kann die Abhänglänge jedes einzelnen Pendels individuell bestimmt werden. Je nach Lust und Laune bieten sich dadurch zahlreiche Gestaltungsmöglichkeiten. Die passende Deckenleuchte ist vielseitig einsetzbar und ideal für kreative Kombinationen.

Modern, timeless design and simple elegance provide the CIVETO light series with a unique charm. The pendant luminaire is available in two different versions and captivates with its successful mix of matte black and light silver aluminium surfaces. The hanging length of each individual endulum can be individually adjusted with ease. Depending on your mood, there are numerous design options. The matching ceiling lamp is versatile and perfect for creative combinations





CIVETO

ZEITLOSES DESIGN
TIMELESS DESIGN

CI·MOTE
ready

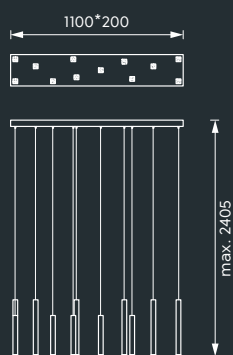

CIVETO

Pendelleuchte, Metall Acryl
Pendant lamp, metal acryl

↔ 1.100 mm ↑ max. 2.405 mm ↗ 200 mm

SMD-LED, 12 x 3,5 W, 12 x 360 lm

2.000 - 4.000 K

373511232 | Schwarz matt · Black mat





CIVETO

ZEITLOSES DESIGN
TIMELESS DESIGN

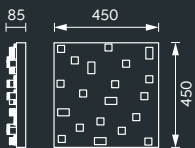
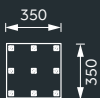
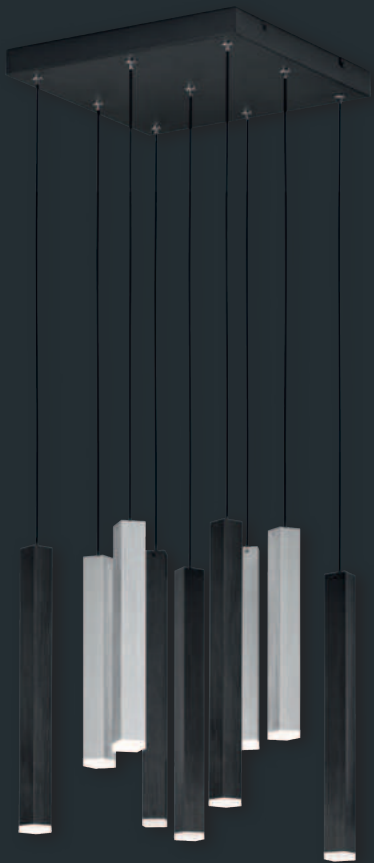

CIVETO

Pendelleuchte, Metall Acryl
Pendant lamp, metal acryl

↔ 350 mm ↑ max. 2.405 mm ↗ 350 mm

SMD-LED, 9 x 3,5 W, 9 x 360 lm

2.000 - 4.000 K

673510932 | Schwarz matt · Black mat



CIVETO

Deckenleuchte, Metall Acryl
Ceiling lamp, metal acryl

↔ 450 mm ↑ 85 mm ↗ 450 mm

SMD-LED, 20 x 3 W, 20 x 320 lm

2.000 - 4.000 K

673512032 | Schwarz matt · Black mat





CIFAVO

HARMONIE VON LICHT UND DESIGN HARMONY OF LIGHT AND DESIGN

Leuchten sind längst nicht mehr nur einfache Lichtquellen. Durch die Symbiose von Technik und Design werden Lichtobjekte zu stilvollen Wohnaccessoires. Das futuristische und kunstvolle Design der Serie CIFAVO demonstriert eindrucksvoll, wie sinnlich Licht inszeniert werden kann. Diese extravaganten Designobjekte akzentuieren Raumdecken und Wände auf einzigartige Weise. Das Besondere: Der Lieferumfang enthält magnetische Dekorelemente, die nach Belieben angeordnet werden können. So entstehen unzählige geometrische Gestaltungsmöglichkeiten und optisch ansprechende Kontraste.

Lights are no longer just simple light sources. The symbiosis of technology and design turns lighting objects into stylish home accessories. The futuristic and artistic design of the CIFAVO series impressively demonstrates how sensually light can be designed. These extravagant design objects accentuate ceilings and walls in a unique way. The special feature: The scope of delivery includes magnetic decorative elements that can be arranged as desired. This creates countless geometric design options and visually appealing contrasts.



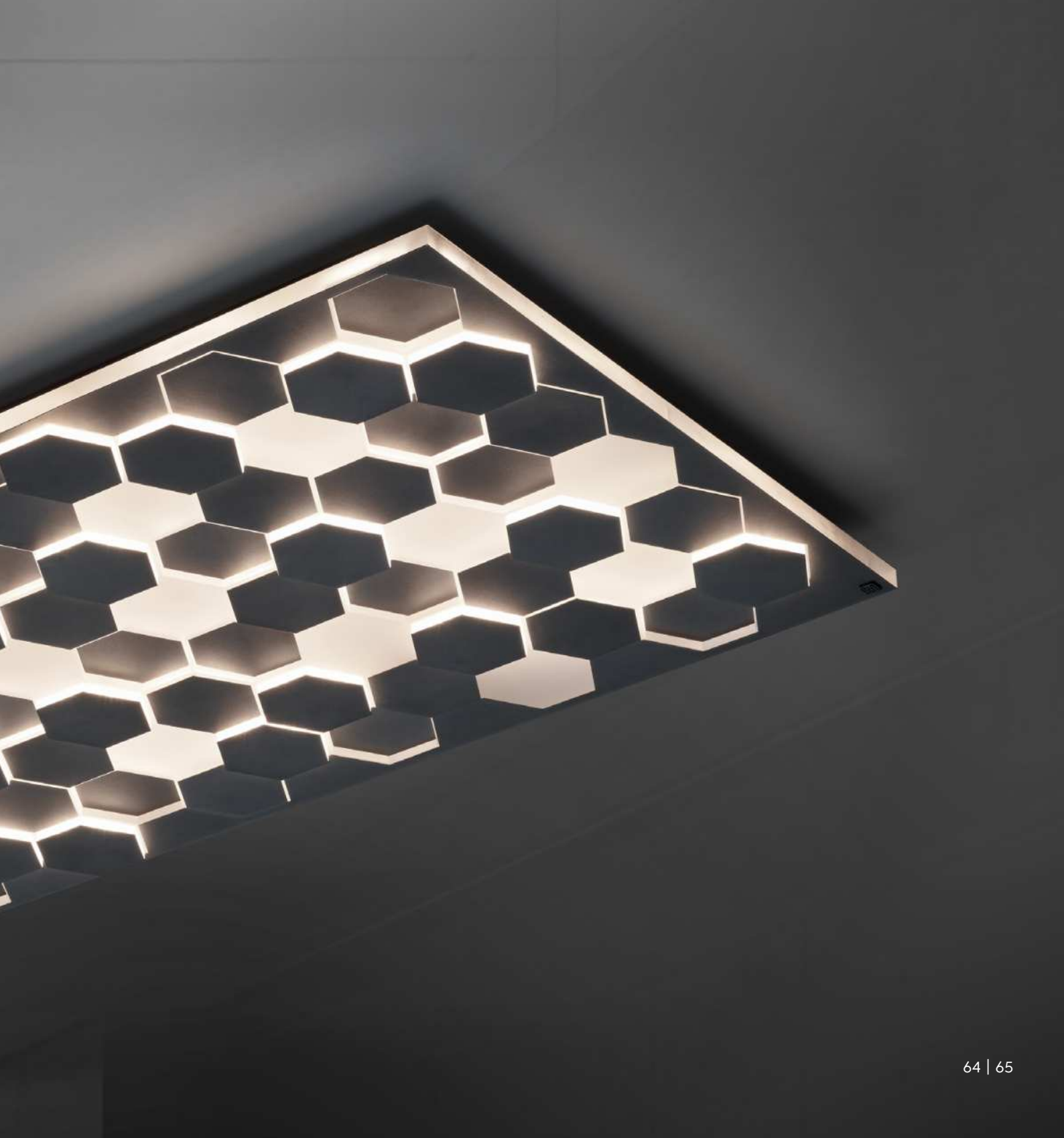

CIFAVO

HARMONIE VON LICHT UND DESIGN
HARMONY OF LIGHT AND DESIGN

CI·MOTE
ready

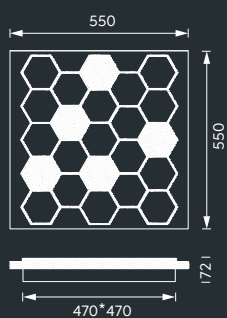
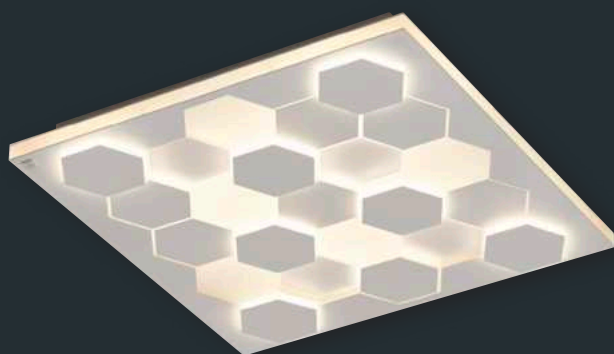

CIFAVO

Wand- und Deckenleuchte, Metall Acryl
Wall and ceiling lamp, metal acryl

↔ 550 mm ↑ 550 mm ↗ 72 mm

SMD-LED, 40 W, 3.780 lm

2.000 - 4.000 K

245410131 | Weiß matt, weiß
White mat, white

245410132 | Schwarz matt, weiß
Black mat, white



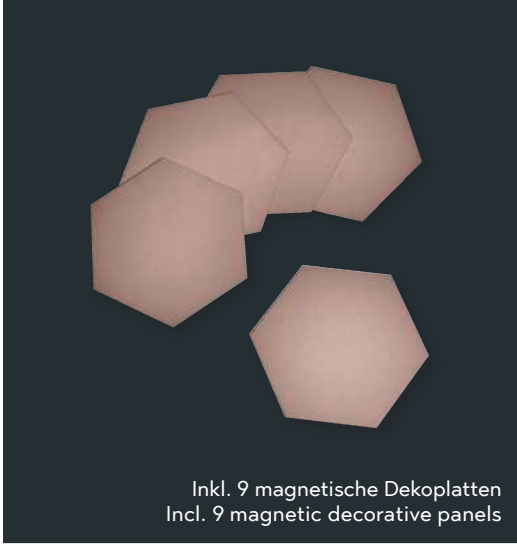

Inkl. 9 magnetische Dekoplaten
Incl. 9 magnetic decorative panels



CIFAVO

HARMONIE VON LICHT UND DESIGN
HARMONY OF LIGHT AND DESIGN

CI-MOTE
ready

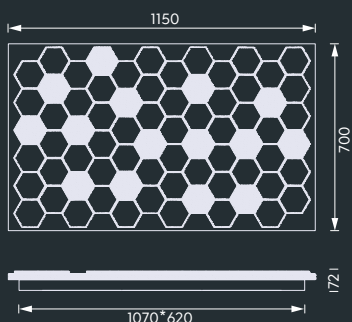
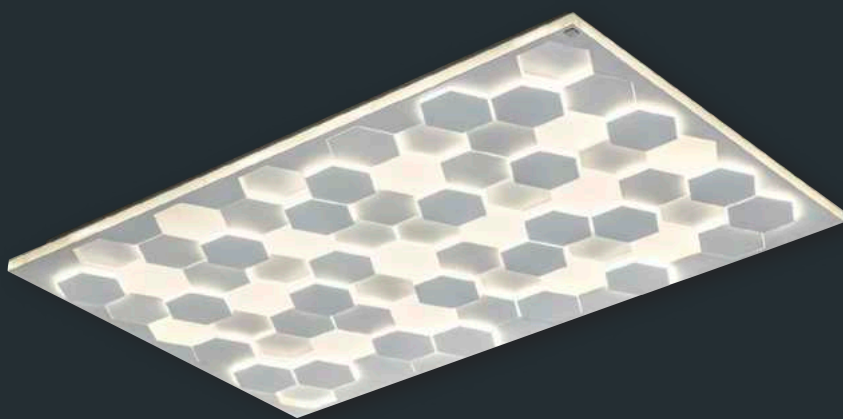

CIFAVO

Wand- und Deckenleuchte, Metall Acryl
Wall and ceiling lamp, metal acryl

↔ 1.150 mm ↓ 700 mm ↗ 72 mm

SMD-LED, 66 W, 6.270 lm

2.000 - 4.000 K

245490131 | Weiß matt, weiß
White mat, white

245490132 | Schwarz matt, weiß
Black mat, white



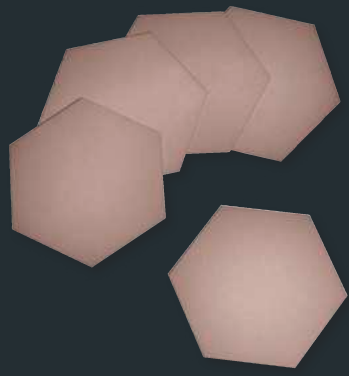

Inkl. 15 magnetische Dekoplatten
Incl. 15 magnetic decorative panels

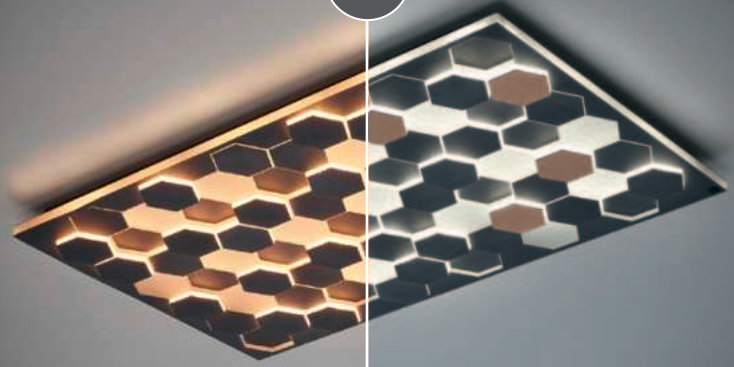

CIZIONE

FUTURISTISCHES DESIGN FUTURISTIC DESIGN

Die CIZIONE Lichtobjekte sind mit ihrem futuristischen Design die ideale Ergänzung für modern gestaltete Wohnkonzepte. Die hocheffizienten LED-Lichtbänder erzeugen ein besonders angenehmes, indirektes Licht, dessen warmer Farbton durch die goldene Lackierung der Innenflächen noch verstärkt wird. Selbst im ausgeschalteten Zustand beeindruckt die Leuchten als eigenständige skulpturale Designobjekte und verleihen jedem Raum eine exklusive Note.

With their futuristic design, the CIZIONE lighting objects are the ideal addition to modern living concepts. The highly efficient LED light strips produce particularly pleasant, indirect light, the warm colour tone of which is further enhanced by the golden finish of the inner surfaces. Even when switched off, the lights impress as independent sculptural design objects and lend any room a visual enhancement.





CIZIONE

FUTURISTISCHES DESIGN
FUTURISTIC DESIGN

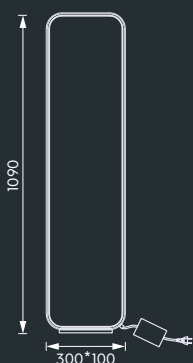

CIZIONE

Stehleuchte, Metall
Floor lamp, metal

↔ 300 mm ↑ 1.090 mm ↗ 100 mm

SMD-LED, 35 W, 4.200 lm

2.000 - 4.000 K

444610131 | Weiß matt, Coffee
White mat, coffee

444610132 | Schwarz matt, goldfarbig
Black mat, gold





CIZIONE

FUTURISTISCHES DESIGN

FUTURISTIC DESIGN

CI-MOTE
ready

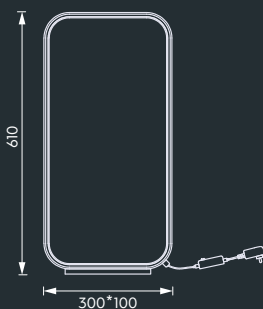
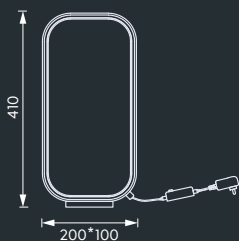
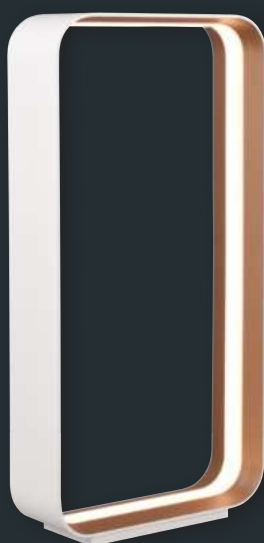

CIZIONE

Tischleuchte, Metall
Table lamp, metal

↔ 200 mm ↑ 410 mm ↗ 100 mm

SMD-LED, 15 W, 1.800 lm

2.000 - 4.000 K

544610131 | Weiß matt, Coffee
White mat, coffee

544610132 | Schwarz matt, goldfarbig
Black mat, gold



CIZIONE

Tischleuchte, Metall
Table lamp, metal

↔ 300 mm ↑ 610 mm ↗ 100 mm

SMD-LED, 20 W, 2.380 lm

2.000 - 4.000 K

544690131 | Weiß matt, Coffee
White mat, coffee

544690132 | Schwarz matt, goldfarbig
Black mat, gold





CIPERA

MODERN UND STILVOLL
STATE-OF-THE-ART AND STYLISH

Die Pendelleuchten CIPERA vereinen modernste Lichttechnik mit stilvollem Glasdesign. Blendfreies homogenes LED-Licht, spielerisch eingefangen in kunstvollem Glas, verleiht den Leuchten einen unverwechselbaren Charakter und lässt sie garantiert zum Blickfang jeder Wohnraumgestaltung werden. Zur Wahl stehen verschiedene Ausführungen in den Kombinationen Weiß mit transparentem Glas und Schwarz mit effektvollem Spiegelglas.

The CIPERA pendant luminaires combine state-of-the-art lighting technology with stylish glass design. Glare-free homogeneous LED light, playfully captured in artistic glass, gives the luminaires a unique character and is guaranteed to make them the eye-catcher of any living room design. There is a choice of different versions in the combinations white with transparent glass and black with effective mirror glass.





CIPERA

MODERN UND STILVOLL
STATE-OF-THE-ART AND STYLISH

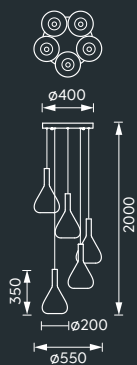

CIPERA

Pendelleuchte, Metall Glas
Pendant lamp, metal glass

↔ Ø 550 mm ↑ 2.000 mm

SMD-LED, 5 x 5,6 W, 5 x 620 lm

2.000 - 4.000 K

345030531 | Weiß matt, transparent
White mat, transparent

345030532 | Schwarz matt, Chrom
bedampft · Black mat, Chrome plated





CIPERA

MODERN UND STILVOLL
STATE-OF-THE-ART AND STYLISH

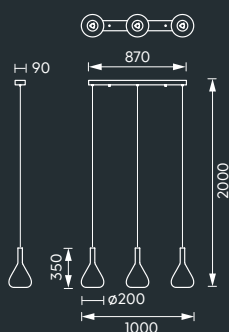

CIPERA

Pendelleuchte, Metall Glas
Pendant lamp, metal glass

↔ 1.000 mm ↓ 2.000 mm ↗ 200 mm

SMD-LED, 3 x 5,6 W, 3 x 620 lm

2.000 - 4.000 K

345010331 | Weiß matt, transparent
White mat, transparent

345010332 | Schwarz matt, Chrom
bedampft · Black mat, Chrome plated





CIPERA

MODERN UND STILVOLL
STATE-OF-THE-ART AND STYLISH

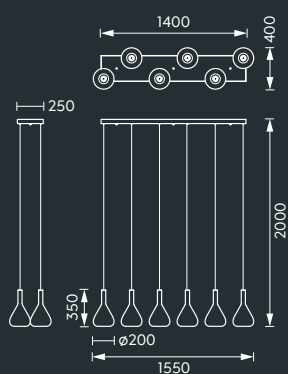

CIPERA

Pendelleuchte, Metall Glas,
Pendant lamp, metal glass

↔ 1.550 mm ↓ 2.000 mm ↗ 400 mm

SMD-LED, 6 x 5,6 W, 6 x 620 lm

2.000 - 4.000 K

345010631 | Weiß matt, transparent
White mat, transparent

345010632 | Schwarz matt, Chrom
bedampft · Black mat, Chrome plated





DIM-TO-WARM

IMMER DIE RICHTIGE STIMMUNG
ALWAYS THE RIGHT MOOD

4.000 K - NEUTRALWEISS | NEUTRAL WHITE

Gute Lichtqualität definiert sich unter anderem durch die Lichtfarbe. Der Begriff „Kelvin“ beschreibt die Lichtfarbe. Je höher dieser Wert ist, desto neutraler bzw. kälter ist das Licht. Unterschiedliche Bedürfnisse verlangen nach individuellen Lichtstimmungen. Für ein Höchstmaß an Wohlbefinden, sind alle Leuchten der Marke CINQUE mit der innovativen Dim-to-Warm Technologie ausgestattet. Gegenüber der herkömmlichen Dimmfunktion, reduziert sich beim Dimmen nicht nur die Lichtstärke, sondern auch die Lichtfarbe. Je weiter die Helligkeit reduziert wird, desto wärmer wird auch das Licht. Für ein helles weißes Licht starten Sie mit 4.000 Kelvin Farbtemperatur. Wünschen Sie eine besonders warme Atmosphäre, dimmen Sie die Farbtemperatur auf 2.000 Kelvin herab – und dies alles stufenlos und absolut flackerfrei.

Good light quality is defined, amongst other things, by the colour temperature. The term “Kelvin” describes the colour temperature. The higher this value, the more neutral or cold the lighting is. Different needs call for individual lighting moods. For maximum physical comfort all CINQUE brand lamps are equipped with the innovative “DIM TO WARM” technology. In contrast to conventional dimming functions, with CINQUE technology it is not just the light intensity that is reduced, but also the colour of the lighting. The more the brightness is reduced, the warmer the light also becomes. For a bright white light, start with a colour temperature of 4000 Kelvin. If you want a particularly warm atmosphere, you can dim the colour temperature down to 2000 Kelvin – and all of this can be done progressively and absolutely flicker-free.





3.000 K - WARMWEISS | WARM WHITE

2.000 K - WARM | WARM



DIM-TO-WARM

FR NL ES IT

DIM-TO-WARM pour une ambiance chaleureuse !

Une bonne qualité de lumière est entre autres déterminée par la couleur de l'éclairage. Le terme "Kelvin" décrit la couleur de l'éclairage. Plus cette valeur est élevée, plus l'éclairage est neutre, ou froid. Des besoins différents appellent des ambiances lumineuses différentes. Pour une convivialité maximale, toutes les lampes de la marque CINQUE sont équipées de la technologie innovante "DIM TO WARM". Contrairement aux fonctions de réglage de l'intensité classiques, avec la technologie CINQUE, ce n'est pas seulement l'intensité lumineuse qui varie, mais également la couleur de l'éclairage. Plus la luminosité est réduite, plus la lumière devient chaude. Pour une lumière blanche brillante, commencez avec une température de couleur de 4000 Kelvin. Si vous êtes à la recherche d'une atmosphère particulièrement chaleureuse, vous pouvez abaisser la température de couleur jusqu'à 2000 Kelvin – et tout cela de manière progressive et sans aucun scintillement.

DIM-TO-WARM voor een gezellige sfeer!

Een goede lichtkwaliteit wordt onder andere bepaald door de kleur van de verlichting. Met de term "kelvin" wordt de kleur van de verlichting beschreven. Hoe hoger deze waarde, des te neutraler of kouder is de verlichting. Verschillende behoeften vereisen individuele verlichtingsstemmingen. Voor maximaal fysiek comfort zijn alle lampen van het merk CINQUE uitgerust met de innovatieve "DIM TO WARM"-technologie. In tegenstelling tot de klassieke dimfuncties wordt met CINQUE-technologie niet alleen de lichtintensiteit verminderd, maar ook de kleur van het licht. Hoe meer de felheid wordt verminderd, des te warmer wordt het licht. Voor een fel wit licht begint u met een kleurtemperatuur van 4000 kelvin. Als u een bijzonder warme sfeer wilt, kunt u de kleurtemperatuur dimmen tot 2000 kelvin. Dit kan allemaal geleidelijk gedaan worden en absoluut zonder flikkeren.

DIM TO WARM para un entorno acogedor.

Una iluminación de buena calidad se define, entre otras cosas, por su color. El término «Kelvin» describe el color de la iluminación. Cuanto más alto sea este valor, más neutra o fría será la iluminación. Diferentes necesidades requieren ambientes de iluminación individuales. Todas las lámparas de la marca CINQUE están equipadas con la innovadora tecnología «DIM TO WARM» para ofrecer el máximo confort. A diferencia de las funciones de atenuación convencionales, la tecnología de las lámparas CINQUE no solo reduce la intensidad de iluminación, sino también su color. Cuanto más se reduce el brillo, más cálida es la luz. Para obtener una luz blanca brillante, empiece por una temperatura del color de 4000 Kelvin. Si desea conseguir un entorno particularmente cálido, puede atenuar la temperatura del color a 2000 Kelvin; ¡y lo mejor es que puede hacerlo de forma progresiva y sin parpadeos!

DIM-TO-WARM per un'atmosfera accogliente!

La buona qualità dell'illuminazione è determinata, tra l'altro, dal suo colore. Il termine "Kelvin" descrive il colore dell'illuminazione. Più questo valore è alto e più l'illuminazione risulta neutra o fredda. Le diverse esigenze richiedono stati d'animo personali in termini di illuminazione. Per il massimo comfort fisico, tutte le lampade del marchio CINQUE sono dotate dell'innovativa tecnologia "DIM TO WARM". Diversamente dalle funzioni di dimmerazione convenzionali, la tecnologia CINQUE non permette solo di modificare l'intensità luminosa, ma anche il colore dell'illuminazione. Più la luminosità si riduce, più calda diventa la luce. Per una luce bianca luminosa, iniziare con una temperatura di colore di 4000 Kelvin. Se si desidera un'atmosfera particolarmente calda, si può abbassare la temperatura di colore fino a 2000 Kelvin – e tutto questo può essere fatto in modo progressivo e senza alcuno sfarfallio.



CI·MOTE

PERFEKTES LICHTERLEBNIS
PERFECT LIGHT EXPERIENCE

*Make it
Smarter*

CI·MOTE – für das perfekte Lichterlebnis

Schon durch die DIM TO WARM-Technik bieten CINQUE-Leuchten hohen Bedienkomfort. Doch es geht noch komfortabler. Mit dem neuen CI·MOTE-Plugin-Modul wird die Lichtsteuerung nicht nur smart, sondern schlichtweg genial. Obendrein ist sie mühelos und schnell installiert.

Das vorhandene DIM TO WARM-Basismodul einfach durch das CI·MOTE-Plugin-Modul ersetzen, und schon lässt sich die Beleuchtung individuellen Vorlieben und Bedürfnissen anpassen. Damit bietet CI·MOTE für jede Raumsituation das perfekte Lichterlebnis.

CI·MOTE – for the perfect light experience

CINQUE luminaires already offer great ease of use thanks to the DIM TO WARM technology. But it can be even more convenient. With the new CI·MOTE plug-in module, lighting control is not only smart, but simply ingenious. On top of that, it is installed effortlessly and quickly.

Simply replace the existing DIM TO WARM base module with the CI·MOTE plug-in module and the lighting can be adapted to individual preferences and needs. CI·MOTE thus offers the perfect lighting experience for every room situation.

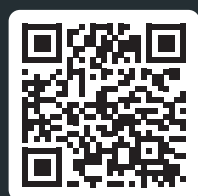

[cinque.lighting/
ci-mote](https://cinque.lighting/ci-mote)





SIMPLE TO SET THE RIGHT AMBIENCE



CI·MOTE

Make it
Smarter

- Steuerung der Leuchten mittels Fernbedienung oder mit der WiZ-App von überall per Smartphone oder Tablet (www.wizconnected.com)
- Helligkeit und Lichtfarbe getrennt voneinander stufenlos regelbar
- Einstellung und Programmierung individueller Lichtszenarien mit Memory-Funktion
- Steuerung über Zeitpläne oder per Sprachbefehle. Kompatibel mit allen gängigen Sprachassistenten wie Amazon Alexa, Google Home oder Siri

- Control of the luminaires by remote control and via the WiZ app
- Brightness and colour temperature separately, infinitely adjustable
- Setting and programming of individual light scenarios with memory function.
- Control via time schedules or voice commands. Compatible with all common voice assistants (Amazon Alexa, Google Home or Siri)

CI·MOTE

WiZ Funk-Fernbedienung, Metall
WiZ Remote control, metal

↔ 83 mm ↑ 103 mm ↗ 12 mm

Akku 3,7 V, 1.000 mAh

FB071-01 | Schwarz matt · Black mat

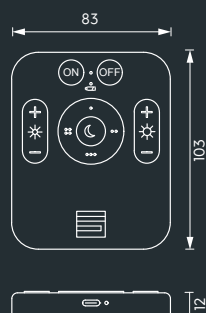

VERBUNDEN MIT DER WIZ-APP CONNECTED BY WIZ

Connected by

WiZ



FERNBEDIENUNG REMOTE CONTROL

- Stufenloses Dimmen
- Lichtfarbe stufenlos einstellbar (2.000 - 4.500 Kelvin)
- 4 verschiedene Lichtszenen auf Knopfdruck
- Nachtlichtfunktion
- USB-C-Ladeanschluss
- Stepless dimming
- Light colour continuously adjustable (2,000 - 4,500 Kelvin)
- 4 different light scenes at the touch of a button
- Night light function



STEUERUNG NACH WUNSCH CONTROL AS YOU LIKE



Steuerung von überall
Control anywhere



Zeitpläne
Schedules



Sprachbefehle
Voice control



Fernbedienung
Remote Control

works with
Siri Shortcuts

works with
alexa

works with
Google Home

LIEFERUMFANG CONTENT

- CI-MOTE-Plugin-Modul
- Elegante Fernbedienung mit USB-C-Ladefunktion
- Praktische Magnet-Wandhalterung
- USB-C Ladekabel
- CI-MOTE plug-in module
- Elegant remote control with USB-C charging function
- Practical magnetic wall mount
- USB-C charging cable



IMMER DIE RICHTIGE STIMMUNG ALWAYS THE RIGHT MOOD

DIMMEN | DIMMING



64.000 WEISSTÖNE
64,000 WHITES

Einstellbare Lichtprogramme
Preset light modes



AMBIENTE EINFACH EINZUSTELLEN SIMPLE TO SET THE RIGHT AMBIENCE

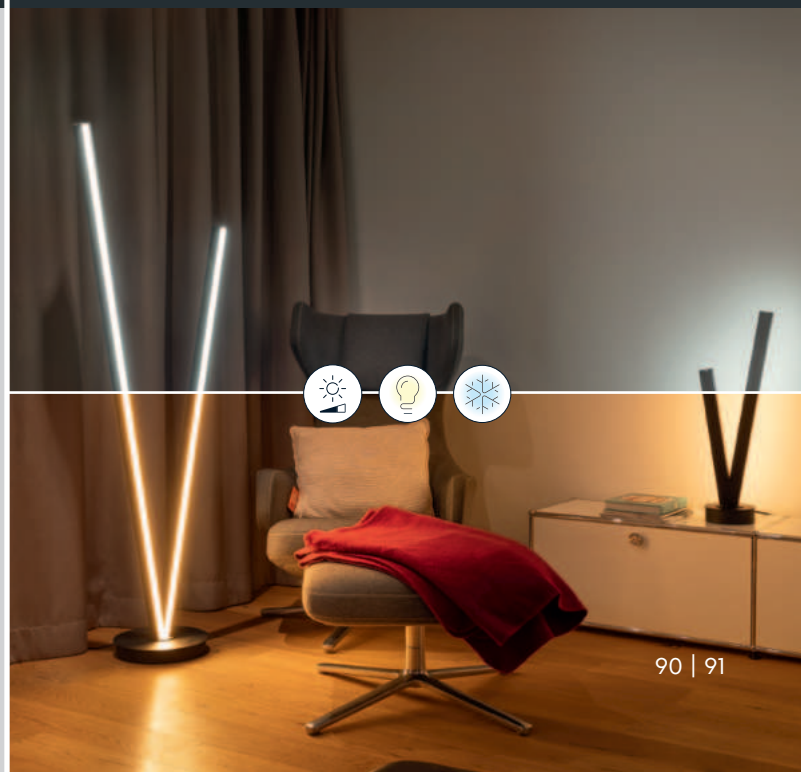

CI·MOTE

Make it
Smarter

FR

CI·MOTE – pour l'expérience lumineuse parfaite

Les luminaires CINQUE offrent déjà une grande facilité d'utilisation grâce à la technologie DIM TO WARM. Mais ils peuvent être encore plus pratiques. Avec le nouveau module enfichable CI·MOTE, le contrôle de l'éclairage n'est pas seulement intelligent mais simplement ingénieux. En outre, ils s'installent sans effort et rapidement. Remplacez simplement le module de base DIM TO WARM par l'unité de contrôle CI·MOTE et l'éclairage peut s'adapter aux préférences et besoins individuels. CI·MOTE offre donc l'expérience lumineuse parfaite pour chaque pièce.

- Contrôle des luminaires par télécommande et via WiZ-app
- Luminosité et couleur des lumières réglables séparément et à l'infini
- Configuration et programmation des ambiances lumineuses individuelles avec fonction mémoire.
- Contrôle selon les heures ou par commande vocale. Compatible avec tous les assistants vocaux courants (Amazon Alexa, Google Home or Siri)

Télécommande

- Variation du flux lumineux
- Couleur des lumières continuellement réglable (2 000 - 4 500 Kelvin)
- 4 ambiances lumineuses différentes en touchant un bouton
- Fonction éclairage nocturne

Contenu

- Module de contrôle enfichable CI·MOTE
- Télécommande élégante avec fonction de charge USB-C
- Montage mural aimanté pratique

NL

CI·MOTE – voor de perfecte lichtervaring

CINQUE-verlichtingstoestellen bieden reeds groot gebruiksgemak dankzij de DIM TO WARM-technologie. Maar het kan zelfs nog handiger zijn. Met de nieuwe CI·MOTE plug-in module is verlichtingsregeling niet enkel smart, maar eenvoudigweg ingenieus. Bovendien wordt het moeiteloos en snel geïnstalleerd. Vervang eenvoudigweg de huidige DIM TO WARM-basismodule met de CI·MOTE-besturingseenheid en de verlichting kan aangepast worden aan individuele voorkeuren en noden. CI·MOTE biedt dus de perfecte verlichtingservaring voor elke kamersituatie.

- Regeling van de verlichtingstoestellen met afstandsbediening en via de WiZ-app
- Helderheid en lichtkleur apart, oneindig aanpasbaar
- Instelling en programmering van individuele lichtscenario's met geheugenfunctie.
- Regeling via tijdschema's of spraakopdrachten. Compatibel met alle gebruikelijke spraakassistenten (Amazon Alexa, Google Home or Siri)

Afstandsbediening

- Staploos dimmen
- Lichtkleur voortdurend aanpasbaar (2.000 - 4.500 Kelvin)
- 4 verschillende lichtscènes bij aanraking van een toets
- Nachtlichtfunctie

Inhoud

- CI·MOTE plug-in regelingsmodule
- Elegante afstandsbediening met USB-C laadfunctie
- Praktische magnetische muurmontage

ES

IT

CI·MOTE: la experiencia de iluminación perfecta

Las lámparas CINQUE ofrecen un uso de gran sencillez gracias a la tecnología DIM TO WARM. No obstante, pueden brindar aún más comodidad con el nuevo módulo enchufable CI·MOTE; este brinda un control de la iluminación inteligente y sencillamente ingenioso. Además, su instalación es rápida y sin esfuerzos. Solo es necesario sustituir el módulo base DIM TO WARM con la unidad de control del CI·MOTE para poder adaptar la iluminación a sus preferencias y necesidades personales. CI·MOTE brinda la experiencia de iluminación perfecta a la estancia para cada situación.

- Control de las lámparas por control remoto a través de la WiZ-app
- Control independiente del brillo y color de la iluminación, totalmente graduable
- Configuración y programación de entornos de iluminación individuales con función memoria.
- Control mediante programación de horarios y comandos por voz. Compatible con todos los asistentes controlados por voz habituales (Alexa de Amazon, Google Home or Siri)

Control remoto

- Atenuación gradual de la luz
- Color de la luz ajustable ininterrumpidamente (2.000 - 4.500 Kelvin)
- 4 escenas de iluminación distintas con solo pulsar un botón
- Función de iluminación nocturna

Contiene

- Módulo de control enchufable CI·MOTE
- Mando a distancia elegante con función de carga mediante USB-C
- Práctico soporte de pared magnético

CI·MOTE – per l'esperienza di illuminazione perfetta

Gli apparecchi CINQUE offrono già una grande facilità d'uso grazie alla tecnologia DIM TO WARM. Ma può essere ancora più comodo. Con il nuovo modulo plug-in CI·MOTE, il controllo della luce non è solo intelligente, ma semplicemente geniale. Inoltre, si installa in modo semplice e veloce. È sufficiente sostituire il modulo base DIM TO WARM esistente con l'unità di controllo CI·MOTE per adattare l'illuminazione alle preferenze e alle esigenze individuali. CI·MOTE offre così un'esperienza di illuminazione perfetta per ogni situazione ambientale.

- Controllo degli apparecchi tramite telecomando e tramite WiZ-app
- Luminosità e colore della luce separati, regolabili in infiniti modi
- Impostazione e programmazione di scenari luminosi individuali con funzione di memoria.
- Controllo tramite programmi orari o comandi vocali. Compatibile con tutti i più comuni assistenti vocali (Amazon Alexa, Google Home or Siri)

Telecomando

- Dimmerazione graduale
- Colore della luce regolabile in continuo (2000 - 614 Kelvin)
- 4 diverse scene di luce con la semplice pressione di un pulsante
- Funzione luce notturna

Contenuto

- Modulo di controllo plug-in CI·MOTE plug-in control module
- Elegante telecomando con funzione di ricarica USB-C
- Pratico supporto magnetico per installazione a parete

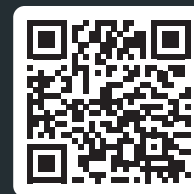

cinque.lighting/
ci-mote

FEATURES | ICONS



Extern dimmbar | Externally dimmable | Dimmable en externe | Uitwendig dimbaar | Regulable externamente | Dimmerabile esternamente | Reglabil extern | Ulkoisesti himmennettävä | Możliwość ściemniania zewnętrznego | Harici olarak kısılabilir | Regulação externa da intensidade da luz | Externt dimbar



Dim to warm | Diminuer pour réchauffer | Dim naar warm | De tenue a cálido | Da fioco a caldo | Dim la cald | Himmeä lämpimäksi | Przyciemniony do ciepłego | Loştan sıcakla | Escuro a quente | Dim till varm



Inklusive Schnurschalter | Cord switch included | Interrupteur à cordon inclus | Inclusief snoerschakelaar | Interruptor con cable incluido | Interruttore a cavo incluso | Întrerupător de cablu inclus | Mukana johtokytkin | Przełącznik przewodowy w zestawie | Kordon anahtarı dahildir | Interruptor com fio incluído | Strömbrytare med sladd ingår



Musterschutz | Design protection | Protection des dessins et modèles | Ontwerpbescherming | Protección del diseño | Protezione del design | Protecția designului | Suunnittelusuojaus | Ochrona konstrukcji | Tasarım koruması | Proteção da concepção | Designskydd



Inklusive Fußschalter | Foot switch included | Pédale de commande incluse | Voetschakelaar inbegrepen | Interruptor de pedal incluido | Interruttore a pedale incluso | Comutator de picior inclus | Mukana jalkakytkin | Przełącznik nożny w zestawie | Ayak pedali dahildir | Interruptor de pé incluído | Fotpedal ingår



Integrierter Dimmer | Integrated dimmer | Variateur intégré | Geïntegreerde dimmer | Regulador de intensidad integrado | Dimmer integrato | Dimmer integrat | Integroitu himmennin | Zintegrowany ściemniacz | Entegre dimmer | Regulador de intensidad integrado | Integrerad dimmer



Ohne Leuchtmittel | Without light source | Sans ampoule | Zonder lichtbron | Sin fuente de luz | Senza sorgente luminosa | Fără sursă de lumină | Ilman valonlähde | Bez źródła światła | Işık kaynağı olmadan | Sem fonte de luz | Utan ljuskälla



LIFT ME: Höhenverstellung ohne Gegengewicht | Height adjustment without counterweight | Réglage de la hauteur sans contrepoids | Hoogteverstelling zonder contragewicht | Regulación de altura sin contrapeso | Regolazione dell'altezza senza contrappeso | Reglarea înălțimii fără contragreutate | Korkeuden säätö ilman vastapainoa | Regulacja wysokości bez przeciwwagi | Karşı ağırlık olmadan yükseklik ayarı | Regulação da altura sem contrapeso | Höjjustering utan motvikt



Schalter | Switches | Interrupteur | Schakelaars | Interruptores | Interruttori | Comutatoare | Kytkimet | Przełączniki | Anahtarlar | Interruptores | Strömbrytare



Up and down Beleuchtung | Up and down lighting | Éclairage up and down | Boven- en benedenverlichting | Iluminación ascendente y descendente | Illuminazione a salire e a scendere | Iluminare în sus și în jos | Ylös ja alas valaistus | Oświetlenie górne i dolne | Yukarı ve aşağı aydınlatma | Iluminação ascendente e descendente | Belysning upp och ner



CI-MOTE kompatibel | CI-MOTE compatible | Compatible avec CI-MOTE | CI-MOTE-compatibel | Compatible con CI-MOTE | Compatibile con CI-MOTE | Compatibil cu CI-MOTE | CI-MOTE-yhteensopiva | Kompatybilny z CI-MOTE | CI-MOTE uyumlu | Compatível com CI-MOTE | Belysning upp och ner

- 07** Nickel matt | Nickel mat | Nikkel mat | Níquel mate | Nichel opaco | Nichel mat | Nikkeli matta |
Nikiel matowy | Nickel mat | Níquel mate
- 31** Weiß matt | White mat | Blanc mat | Wit mat | Blanco mate | Bianco opaco | Alb mat | Valkoinen matta |
Biały matowy | Beyaz mat | Branco mate | Vit matt
- 32** Schwarz matt | Black matt | Noir mat | Zwart mat | Negro mate | Nero opaco | Negro mat | Musta matta |
Czarny matowy | Siyah mat | Preto mate | Svart matt
- 41** Taupe | Taupe | Taupe | Taupe | Topo | Taupe | Taupe | Taupe | Taupe | Taupe | Taupe | Taupe
- 43** Warm beige | Warm beige | beige chaud | Warm beige | Beige cálido | Beige caldo | Bej cald |
Lämmin beige | Ciepły beż | Sıcak bej | Bege quente | Varm beige
- 68** Dark chocolate | Chocolat noir | Zwarte chocolade | Chocolate negro | Cioccolato fondente | Ciocolată neagră |
Tumma suklaa | Ciemna czekolada | Bitter çikolata | Chocolate preto | Mörk choklad

INDEX

Art-Nr.	EAN	Familie Family	Serie Series	Farbe Colour	CI-MOTE ready	Seite Page
336119107	4017807664348	Pendelleuchte Pendant lamp	CISENNA	●	CI-MOTE ready	8
336119132	4017807664324	Pendelleuchte Pendant lamp	CISENNA	●	CI-MOTE ready	8
336119143	4017807664331	Pendelleuchte Pendant lamp	CISENNA	●	CI-MOTE ready	8
336130107	4017807664317	Pendelleuchte Pendant lamp	CISENNA	●	CI-MOTE ready	10
336130132	4017807664294	Pendelleuchte Pendant lamp	CISENNA	●	CI-MOTE ready	10
336130143	4017807664300	Pendelleuchte Pendant lamp	CISENNA	●	CI-MOTE ready	10
636110107	4017807664461	Deckenleuchte Ceiling lamp	CISENNA	●	CI-MOTE ready	12
636110132	4017807664447	Deckenleuchte Ceiling lamp	CISENNA	●	CI-MOTE ready	12
636110143	4017807664454	Deckenleuchte Ceiling lamp	CISENNA	●	CI-MOTE ready	12
436110107	4017807664409	Stehleuchte Floor lamp	CISENNA	●	CI-MOTE ready	14
436110132	4017807664386	Stehleuchte Floor lamp	CISENNA	●	CI-MOTE ready	14
436110143	4017807664393	Stehleuchte Floor lamp	CISENNA	●	CI-MOTE ready	14
536110107	4017807664430	Tischleuchte Table lamp	CISENNA	●	CI-MOTE ready	14
536110132	4017807664416	Tischleuchte Table lamp	CISENNA	●	CI-MOTE ready	14
536110143	4017807664423	Tischleuchte Table lamp	CISENNA	●	CI-MOTE ready	14
346110107	4017807579505	Pendelleuchte Pendant lamp	CINARDI	●	CI-MOTE ready	18
346110132	4017807579499	Pendelleuchte Pendant lamp	CINARDI	●	CI-MOTE ready	18
346110141	4017807636789	Pendelleuchte Pendant lamp	CINARDI	●	CI-MOTE ready	18
346110168	4017807636796	Pendelleuchte Pendant lamp	CINARDI	●	CI-MOTE ready	18
446110107	4017807579536	Stehleuchte Floor lamp	CINARDI	●	CI-MOTE ready	20
446110132	4017807579512	Stehleuchte Floor lamp	CINARDI	●	CI-MOTE ready	20
446110141	4017807636802	Stehleuchte Floor lamp	CINARDI	●	CI-MOTE ready	20
446110168	4017807636819	Stehleuchte Floor lamp	CINARDI	●	CI-MOTE ready	20
546110107	4017807579567	Tischleuchte Table lamp	CINARDI	●	CI-MOTE ready	20
546110132	4017807579550	Tischleuchte Table lamp	CINARDI	●	CI-MOTE ready	20
546110141	4017807636826	Tischleuchte Table lamp	CINARDI	●	CI-MOTE ready	20
546110168	4017807636833	Tischleuchte Table lamp	CINARDI	●	CI-MOTE ready	20
246110107	4017807664270	Wandleuchte Wall lamp	CINARDI	●	CI-MOTE ready	22
246110132	4017807664256	Wandleuchte Wall lamp	CINARDI	●	CI-MOTE ready	22
646110107	4017807664249	Deckenleuchte Ceiling lamp	CINARDI	●	CI-MOTE ready	22
646110132	4017807664232	Deckenleuchte Ceiling lamp	CINARDI	●	CI-MOTE ready	22
377210107	4017807471717	Pendelleuchte Pendant lamp	CIOLA	●	CI-MOTE ready	26
377210132	4017807471755	Pendelleuchte Pendant lamp	CIOLA	●	CI-MOTE ready	26
377210141	4017807636840	Pendelleuchte Pendant lamp	CIOLA	●	CI-MOTE ready	26
677210107	4017807471786	Deckenleuchte Ceiling lamp	CIOLA	●	CI-MOTE ready	28
677210132	4017807471779	Deckenleuchte Ceiling lamp	CIOLA	●	CI-MOTE ready	28
677210141	4017807636857	Deckenleuchte Ceiling lamp	CIOLA	●	CI-MOTE ready	28
477210107	4017807471649	Stehleuchte Floor lamp	CIOLA	●	CI-MOTE ready	30
477210132	4017807471687	Stehleuchte Floor lamp	CIOLA	●	CI-MOTE ready	30
577210107	4017807471601	Tischleuchte Table lamp	CIOLA	●	CI-MOTE ready	30
577210132	4017807471632	Tischleuchte Table lamp	CIOLA	●	CI-MOTE ready	30
455810207	4017807621372	Stehleuchte Floor lamp	CIVASTO	●	CI-MOTE ready	34
455810232	4017807621365	Stehleuchte Floor lamp	CIVASTO	●	CI-MOTE ready	34
455810243	4017807621389	Stehleuchte Floor lamp	CIVASTO	●	CI-MOTE ready	34
467900132	4017807621419	Stehleuchte Floor lamp	CIALTO	●		38
467900143	4017807628173	Stehleuchte Floor lamp	CIALTO	●		38
335710107	4017807664003	Pendelleuchte Pendant lamp	CIMOLTO	●	CI-MOTE ready	42
335710132	4017807663969	Pendelleuchte Pendant lamp	CIMOLTO	●	CI-MOTE ready	42
335719107	4017807664065	Pendelleuchte Pendant lamp	CIMOLTO	●	CI-MOTE ready	42
335719132	4017807664027	Pendelleuchte Pendant lamp	CIMOLTO	●	CI-MOTE ready	42
378510232	4017807471878	Pendelleuchte Pendant lamp	CICENZA	●	CI-MOTE ready	46
478510132	4017807471854	Stehleuchte Floor lamp	CICENZA	●		48
578510132	4017807471830	Tischleuchte Table lamp	CICENZA	●		48
375010107	4017807543100	Pendelleuchte Pendant lamp	CICANTO	●	CI-MOTE ready	52
375010132	4017807543094	Pendelleuchte Pendant lamp	CICANTO	●	CI-MOTE ready	52
675010107	4017807543131	Deckenleuchte Ceiling lamp	CICANTO	●	CI-MOTE ready	54
675010132	4017807543124	Deckenleuchte Ceiling lamp	CICANTO	●	CI-MOTE ready	54
475010107	4017807543285	Stehleuchte Floor lamp	CICANTO	●	CI-MOTE ready	56
475010132	4017807543278	Stehleuchte Floor lamp	CICANTO	●	CI-MOTE ready	56
575010107	4017807543339	Tischleuchte Table lamp	CICANTO	●	CI-MOTE ready	56
575010132	4017807543315	Tischleuchte Table lamp	CICANTO	●	CI-MOTE ready	56

INDEX

Art-Nr.	EAN	Familie Family	Serie Series	Farbe Colour	CI-MOTE ready	Seite Page
373511232	4017807471526	Pendelleuchte Pendant lamp	CIVETO	●	CI-MOTE ready	60
373510932	4017807471496	Pendelleuchte Pendant lamp	CIVETO	●		62
673512032	4017807471540	Deckenleuchte Ceiling lamp	CIVETO	●		62
245410131	4017807579482	Wandleuchte Wall lamp	CIFAVO	○	CI-MOTE ready	66
245410132	4017807579475	Wandleuchte Wall lamp	CIFAVO	●	CI-MOTE ready	66
245490131	4017807579468	Wandleuchte Wall lamp	CIFAVO	○	CI-MOTE ready	68
245490132	4017807579451	Wandleuchte Wall lamp	CIFAVO	●	CI-MOTE ready	68
444610131	4017807578393	Stehleuchte Floor lamp	CIZIONE	○	CI-MOTE ready	72
444610132	4017807578423	Stehleuchte Floor lamp	CIZIONE	●	CI-MOTE ready	72
544610131	4017807578379	Tischleuchte Table lamp	CIZIONE	○	CI-MOTE ready	74
544610132	4017807578409	Tischleuchte Table lamp	CIZIONE	●	CI-MOTE ready	74
544690131	4017807578386	Tischleuchte Table lamp	CIZIONE	○	CI-MOTE ready	74
544690132	4017807578416	Tischleuchte Table lamp	CIZIONE	●	CI-MOTE ready	74
345030531	4017807542875	Pendelleuchte Pendant lamp	CIPERA	○		78
345030532	4017807542868	Pendelleuchte Pendant lamp	CIPERA	●		78
345010331	4017807555899	Pendelleuchte Pendant lamp	CIPERA	○		80
345010332	4017807555905	Pendelleuchte Pendant lamp	CIPERA	●		80
345010631	4017807542950	Pendelleuchte Pendant lamp	CIPERA	○		82
345010632	4017807542929	Pendelleuchte Pendant lamp	CIPERA	●		82
FB071-01	4017807552881	Funkfernbedienung Remote control	CI-MOTE	●		90

TRIO Leuchten GmbH

Gut Nierhof 17
D-59757 Arnsberg
T +49 2931 9666-0
F +49 2931 9666-28
info@trio-leuchten.de
www.trio-leuchten.de

DEUTSCHLAND

BADEN WÜRTTEMBERG,
RHEINLAND-PFALZ UND SAARLAND

Antonio De Simone
T +49 (0) 151 5855222
antonio.desimone@trio-leuchten.de

BAYERN, HESSEN

Martin Kluge
T +49 (0) 171 7300330
martin.kluge@trio-leuchten.de

BERLIN, BRANDENBURG
MECKLENBURG-VORPOMMERN,
SACHSEN, SACHSEN-ANHALT,
THÜRINGEN

Jörg Bumke
T +49 (0) 160 7406860
joerg.bumke@trio-leuchten.de

BREMEN, HAMBURG, NIEDERSACHSEN,
SCHLESWIG-HOLSTEIN

Jens Gebers
T +49 (0) 170 1615227
jens.gebers@trio-leuchten.de

HESSEN, NORDRHEIN-WESTFALEN,
RHEINLAND-PFALZ

Christian Teller
T +49 (0) 171 4521820
christian.teller@trio-leuchten.de

ÖSTERREICH

Wolfgang Melich
T +43 (0) 660 5161228
wolfgang.melich@trio-leuchten.de

SCHWEIZ

TRIO Leuchten GmbH
T +49(0)2931 9666 99
info@trio-leuchten.de

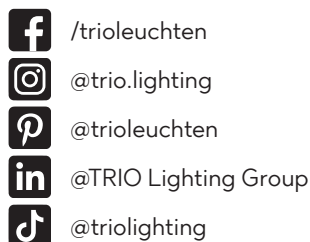

cinque.lighting

TRIO International GmbH

Gut Nierhof 17
D-59757 Arnsberg
T +49 2931 9666-587
F +49 2931 9666-56
info@trio-lighting.com
www.trio-lighting.com

FRANCE

Stéphane Papierny
Directeur commercial France
info.france@trio-lighting.com

Julien Lamouret
Chef de Produits et Directeur des
Ventes France GSB

Jean Barel
Agent commercial pour les départements
09, 12, 15, 16, 19, 24, 31, 32, 33, 40, 46,
47, 64, 65, 81, 82 et 87

Daho Bekhti
Agent commercial pour les départements
02, 59, 60, 62 et 80

Jean Marc Beneforti
Agent commercial pour les départements
2a et 2b

Sylvain Martin
Agent commercial pour les territoires
des DROM-COM

Christophe Meulien
Agent commercial pour les départements
04, 05, 06, 11, 13, 30, 34, 66, 83, 84 et 98

Sullivan Nicolas
Commercial pour les départements
01, 03, 07, 21, 23, 26, 38, 39, 42,
43, 48, 63, 69, 71, 73 et 74

Stéphane Riebel
Agent commercial pour les départements
18, 27, 28, 45, 58, 75, 76, 77, 78, 89, 91,
92, 93, 94 et 95

Michel Salamand
Agent commercial pour les départements
14, 17, 22, 29, 35, 36, 37, 41, 44, 49, 50,
53, 56, 61, 72, 79, 85 et 86

Vincent Zaepffel
Commercial pour les départements
08, 10, 25, 51, 52, 54, 55, 57, 67,
68, 70, 88 et 90

BELGIUM

**Yves Van den Berghe / Frank Boesmans /
Pauline Delorme**
info.belgium@trio-lighting.com

DENMARK

Jan Rantzau-Bartens
info.denmark@trio-lighting.com

NETHERLANDS

Karl Stok / Bas Martin
info.nederland@trio-lighting.com

ROMANIA

Loredana Barbu
T (+40) 741 788 674
info.romania@trio-lighting.com

GREAT BRITAIN

TRIO Lighting UK Ltd.
Unit 5, Hemmells Park Hemmells,
Laindon Essex
SS1s 6GF
T +44 (0) 12 68 88 95 95
F +44 (0) 12 68 88 95 96
sales@triolightinguk.com

ITALY

TRIO Lighting Italia s.r.l.
Via Isonzo, 81
22066 Mariano Comense (CO)
T +39 (0) 317 477 55
F +39 (0) 313 551 560
commerciale@trio-lighting.com

NORDIC AND BALTIC

TRIO Lighting Scandinavia Oy
Malmin raitti, rappu 17 B
00700 Helsinki
T +358 (0) 10 23 13 390
TLS@trio-lighting.com
Our Scandinavian organisation represents TRIO also in
Estonia, Iceland, Latvia, Lithuania, Norway and Sweden

SPAIN

TRIO Lighting Ibèrica S.L.
C/VALLÉSPIR 19, Plta 2, módulo 1.1
08173 Sant Cugat del Vallès
T +34 (0) 935 458 630
info.iberica@trio-lighting.com

AFRICA

F&M Global
T (+32) 4719 22111
hans.deserranno@fmglobal.be
Ina Concept
T (+32) 4719 94693
jerome.freri@ina-concept.com

ALBANIA

Kika Light
T (+355) 672 084 781
kika1light@gmail.com

BOSNIA AND HERZEGOVINA

GRIČ d.o.o.
T (+38) 7039 706 658
daniel.martinovic@tel.net.ba

BULGARIA

ATG Bulgaria
T (+359) 899 927 707
deyana_petrova@atg-apa.net

CZECH REPUBLIC

Luminex spol. s.r.o.
T (+42) 777 570 560
objednavky@luminex.cz

GREECE / CYPRUS

Solomon Lighting S.A.
T (+30) 21060 46003
alberto@solomongroup.gr

HUNGARY

Luxera Kft.
T (+36) 83 3163 88
info@trio-lampa.hu

KOSOVO

ACN
T (+383) 44 344 434
info@acn-ks.com

NORTH MACEDONIA

Elektro Megavat
T (+389) 71665006
contact@megalight.com.mk

POLEN

Delighting Polska sp. z.o.o.
T (+48) 61 4367 481
kontakt@delighting.pl

REPUBLIC OF MOLDOVA

Volta LTD
T (+37) 322 26 7775
import5@volta.md

SERBIA

Aura Light d.o.o. Novi Sad
T (+38) 121 2100724
aura.lightdoo@gmail.com

SLOVAKIA

Feim SK s.r.o.
T (+42) 134 7743 228
svietidla@feim.sk

SLOVENIA

BT Trade d.o.o.
T (+386) 41 676 006
info@butiksvetil.si

TURKEY

Soho Aydinlatma Ticaret Ltd.
T (+90) 2165 7669 41
kartal.kendirci@soholight.com

UKRAINE

MAX Light
T (+38) 4446 37942
tanya@maxlight.ua



